

**RESOLUTION APPROVING A CONTRACT WITH RONYAK PAVING INC. FOR FOOTVILLE RICHMOND ROAD CH 12 PHASE I SECTION F-H AND PHASE II SECTION D-F ROAD FOR CRACK AND SEAT AND PAVING PROJECT FOR THE COUNTY HIGHWAY/ENGINEER DEPARTMENT, QUOTATION # 318**

WHEREAS, Tim Martin, Ashtabula County Engineer, has presented a Contract for the approval if the Board, to-wit:

**Scope of Contract:** Footville Richmond road crack and seat and paving phase I and phase II for Ashtabula County Engineers, Highway Department

**Provider:** Ronyak Paving Inc., P.O. Box, Burton, Ohio 44021

**Cost:** **Not to Exceed: \$1,666,474.00**

**Term:** 1 year from date of execution

THEREFORE, BE IT RESOLVED, By the Board of Commissioners of Ashtabula County, Ohio that the contract is approved in accordance with a copy of said contract now on file in this office.

**ASHTABULA COUNTY COMMISSIONERS  
CERTIFICATION PAGE**

**Resolution No. 2024-306**

**June 20, 2024**

**RESOLUTION APPROVING A CONTRACT WITH RONYAK PAVING INC. FOR FOOTVILLE RICHMOND ROAD CH 12 PHASE I SECTION F-H AND PHASE II SECTION D-F ROAD FOR CRACK AND SEAT AND PAVING PROJECT FOR THE COUNTY HIGHWAY/ENGINEER DEPARTMENT, QUOTATION # 318**

**Upon the motion of J.P. Ducro IV, seconded by Casey R. Kozlowski.**

**VOTE:**

**Kathryn L. Whittington  
J.P. Ducro IV  
Casey R. Kozlowski**

**Aye  
Aye  
Aye**

**CERTIFICATE OF CLERK**

IT IS HEREBY CERTIFIED that the foregoing is a true and correct transcript of a resolution acted upon and duly passed by the Board of County Commissioners of Ashtabula County, Ohio, on the date noted above.



---

Lisa Hawkins, Clerk of the Board  
Board of County Commissioners  
Ashtabula County, Ohio

**OFFICE OF THE COUNTY ENGINEER**

**PROPOSAL**

**TO THE BOARD OF COUNTY COMMISSIONERS COUNTY OF ASHTABULA**

For: Footville Richmond Road  
Cracking & Seating Concrete Pavement & Asphalt Paving

Bidder's Name Ronyak Paving Inc

Street Address 14376 N. Cheshire St.

P.O. Box N/A

City, State & zc Buxton, OH 44021

Quotation No. 318

Location: Footville-Richmond Rd, Rock Creek, OH 44084

Date of Letting: May 23, 2024

Place of Letting: Ashtabula County Engineer's Office

186 East Satin Street

Jefferson, Ohio 44047

Completion Date: November 8, 2024

ENGINEER'S ESTIMATE \$1,700,009.00

Contractor's Total Cost & Expense \$ 1,666,474.00

**BID DOCUMENTS**

**Table of Contents**

<b><u>DESCRIPTION</u></b>	<b><u>PAGE</u></b>
Cover Sheet (for County Engineer use only)	i
Proposal Title Sheet	ii
Table of Contents	iii
Advertisement; Notice to Bidders	v
<b>I. Instructions to Bidders</b>	<b>1</b>
1. Submission of Bids	1
2. Standard Specifications & Terms	1
3. Form of Bid	2
4. Bidder Qualifications	2
5. Examination of Specifications, Site, Etc.	2
6. Bid Guarantee	3
7. Factors for Acceptance or Rejection of Bids	3
8. Withdrawal of Bids	3
9. Domestic Use Requirements; Load Bearing Structural Steel	4
10. Prevailing Wage Rates	4
11. Other Costs & Requirements	4
<b>II. Supplemental Instructions to Bidders</b>	<b>5</b>
1. Bidder Preferences (if any)	5
2. Additional Bidder Prequalification Requirements (if any)	5
3. Other Supplemental Instructions to Bidders	5
<b>III. Supplemental Contract Provisions</b>	<b>6</b>
1. Award Requirements of Successful Bidder / Contractor	6
2. Other Contractor Duties	7

3. Discrimination Prohibited	7
4. Inspection	8
5. Changes in Quantity of Work	9
6. No Waiver of Rights	9
7. Damages for Late Completion; Extensions of Time	10
8. Night & Sunday Work	10
9. Other Supplemental Contract Provisions	10
IV. Scope of Work	11
1. Generally	11
2. Schedule of Performance	11
3. Description of Scope of Work	11
V. Plans & Specifications	12
1. Generally	12
2. "Or Equal"	12
3. List of Plans & Specifications	12
VI. Prevailing Wage Rate Schedules	12
VII. Proposal Forms (to be completed by bidder)	13
1. Equal Employment Opportunity Compliance Certificate	13-14
2. Declaration: Personal Property Tax Delinquency	15
3. Certificate: Unresolved Findings of Recovery	16
4. Campaign Contributions Limitations Certification	17-18
5. Proposal	19-20
6. Bid Prices; Planned Bid Items & Quantities	21
VIII. Articles of Agreement, Prosecutor & Commissioner Signature Page	22-25
1. Fiscal Officer's Certificate	26

**LEGAL NOTICE  
NOTICE TO BIDDERS**

Sealed bids will be received by the Ashtabula County Engineer on behalf of the Board of County Commissioners at the County Engineer's Office, 186 East Satin St., Jefferson, Ohio 44047 until 10:00 A.M. on the 23rd day of May 2024 at which time said bids will be opened and publicly read for Footville Richmond Road C.H. 12, Phase I Section F-H and Phase II Section D-F Crack and Seat and Paving in Morgan/Trumbull Township, for the Ashtabula County Engineer's Department in accordance with the specifications on file in the Engineer's Office on Quotation #318.

Any supplemental information desired by the Bidder may be obtained at the Ashtabula County Engineer's Office, 186 East Satin St., Jefferson, Ohio 44047 (440-576-3707).

Each bid shall contain the full name of each person or company submitting a bid and shall be accompanied by either:

- (1) A bond in accordance with division (B) of the ORC 153.54 for the full amount of the bid; or
- (2) a certified check, cashiers check. The amount of the certified check or cashiers check shall be equal to 10% of the bid, as security that if a bid is accepted delivery is assured.

Bidders are advised that HB 308 rules apply. Contractors or suppliers shall furnish MSDS sheets for any hazardous substance brought onto county property or a county job site.

**\*THIS PROJECT IS PARTIALLY FUNDED WITH OPWC FUNDS.**

Domestic steel use requirements as specified in Section 153.001 of the Ohio Revised Code apply to this project. Copies of Section 153.001 of the Ohio Revised Code can be obtained from any of the offices of the Ohio Department of Administrative Services.

The Notice to Bidders and/or the specifications may be obtained via the internet at [www.ashtabulacounty.us/bids](http://www.ashtabulacounty.us/bids)

Each bid must be in a sealed envelope and the outside thereof properly marked with the Quotation Number, Date and Time of the bid opening.

The Board of Commissioners reserves the right to waive any and all informalities and the right to reject any and all bids.

By order of the Board of Commissioners of Ashtabula County, Ohio: J.P. Ducro IV, Casey Kozlowski, and Kathryn Whittington.

Timothy T. Martin  
Ashtabula County Engineer

**STATE OF OHIO EQUAL EMPLOYMENT OPPORTUNITY**  
**REQUIREMENTS AND BID CONDITIONS FOR**  
**OPWC-ASSISTED CONSTRUCTION PROJECTS**

The attached materials are provided for use by local subdivisions in receipt of financial assistance from the Ohio Public Works Commission for the development or redevelopment of capital infrastructure improvements. The materials relate to the State of Ohio's equal employment opportunity requirements for contractors when they participate in State-assisted construction projects.

These materials must be inserted into the contracting subdivision's bidding documents for such State-assisted projects, and must be regarded as an integral component of the bidder's response. The bidder must, as a part of its bid response: elect one of the two Bidder's Affirmative Action Requirements, adopt the Bidder's EEO Covenants, and complete the Bidder's Certification. Failure to complete the required sections may cause the bidder's proposal to be rejected as being non-responsive to the State's Equal Employment Opportunity Requirements and in non-compliance with the State Equal Employment Opportunity Bid Conditions. In addition, the bidder must submit a copy of a valid Certificate of Compliance for Equal Employment Opportunity purposes prior to the execution of a contract.

Should there be any questions regarding the use or meaning of any portion of these materials, the best answers can be received from the Equal Opportunity Center at 77 South High Street, 24th Floor, Columbus, Ohio 43266-0408. Phone: (614) 466-8380.

**STATE OF OHIO EQUAL EMPLOYMENT OPPORTUNITY REQUIREMENTS**

**AND BID CONDITIONS FOR**

**OPWC-ASSISTED CONSTRUCTION PROJECTS**

**NOTICE TO CONTRACTORS:**

The provisions of the Ohio Administrative Code 123:2-3-02 regarding Equal Employment Opportunity on State Construction Contracts and State-assisted Construction Contracts, and the Ohio Administrative Code 123:2-3-02 regarding Equal Employment Opportunity and Female Utilization Goals are applicable to this project, and each contractor will be required to comply in all aspects to the provisions of said executive orders.

**CERTIFICATE OF COMPLIANCE FOR EEO PURPOSES:**

All prime contract bidders on the project must submit prior to the execution of a contract a copy of a valid Certificate of Compliance for Equal Employment Opportunity purposes as issued by the State Equal Employment Opportunity Coordinator.

>>> Does this bidder have a valid Certificate of Compliance?  Yes  No

>>> If "No" to the above, will this bidder be able to obtain a valid Certificate of Compliance prior to the execution of a contract?  Yes  No

Bidder must provide a "Yes" answer to one or the other of the above questions.

**BIDDER'S AFFIRMATIVE ACTION REQUIREMENTS:**

Each prime contract bidder must submit an Affirmative Action Program regarding equal employment opportunity to and receive approval from the State Equal Employment Opportunity Coordinator prior to the bid opening, OR the prime contract bidder must evidence within its bid the adoption of the Minority Manpower Utilization Goals and Timetables set forth in "Appendix A" and the Specific Affirmative Action Steps set forth in "Appendix B" of the State Equal Employment Opportunity Bid Conditions.

>>> The prime contract bidder has prepared and submitted an Affirmative Action Program to the State Equal Employment Opportunity Coordinator and that program has been approved by the State Equal Employment Opportunity Coordinator prior to the bid opening?  Yes  No

O R

>>> With this bid response, the prime contract bidder hereby adopts the Minority Manpower Utilization Goals and Timetables set forth in Appendix "A" and the Specific Affirmative Action Steps set forth in Appendix "B" of the State Equal Employment Opportunity Bid Conditions?  Yes  No

Bidder must provide a "Yes" answer to one or the other of the above affirmative action alternatives.

## BIDDER'S EEO COVENANTS:

Throughout its performance of any contract awarded to it on this State-assisted project, the prime contract bidder agrees to the following covenants:

- (1) The contractor will not discriminate against any employee or applicant for employment because of race, color, religion, national origin, ancestry or sex. The contractor will take affirmative action to ensure that applicants are employed, and that employees are treated during employment without regard to their race, color, religion, national origin, ancestry or sex. Such action shall include, but is not limited to, the following: Employment, upgrading, demotion, or transfer; recruitment or recruitment advertising; layoff or termination; rates of pay or other forms of compensation; and selection for training, including apprenticeship.  
  
The contractor agrees to post in conspicuous places, available to employees and applicants for employment, notices to be provided setting forth the provisions of this nondiscrimination clause.
- (2) The contractor will in all solicitations or advertisements for employees placed by or on behalf of the prime contractor, state that all qualified applicants will receive consideration for employment without regard to race, color, religion, national origin, ancestry or sex.
- (3) The contractor will send to each labor union or representative of workers with which it has a collective bargaining agreement or other contract or understanding, a notice to be provided by the State Administering Agency advising the said labor union or workers' representatives of the contractor's commitments under this covenant and shall post copies of the notice in conspicuous places available to employees and applicants for employment.
- (4) The contractor will comply with all provisions of the Ohio Department of Administrative Services, Division of Public Works' Regulations on Equal Employment Opportunity (hereinafter DEW Regulations) and with the implementing rules, regulations and applicable orders of the State Equal Employment Opportunity Coordinator.
- (5) The contractor agrees to fully cooperate with the State Administering Agency, the State Equal Employment Opportunity Coordinator and with any other official or agency, or the State or Federal government which seeks to eliminate unlawful employment discrimination, and with all other State and Federal efforts to assure equal employment practices under its contract and the contractor shall comply promptly with all requests and directions from the State Administering Agency, the State Equal Employment Opportunity Coordinator and any of the State of Ohio officials and agencies in this regard, both before and during construction.
- (6) Full cooperation as expressed in clause (5), above, shall include, but not be limited to, being a witness and permitting employees to be witnesses and complainants in any proceeding involving questions of unlawful employment practices, furnishing all information and monthly utilization work hour reports (OAC 123:2-9-01) required by the DEW Regulations and by the rules, regulations and orders of the State Equal Employment Opportunity Coordinator pursuant thereto, and permitting access to its books, records, and accounts by the State Administering Agency and the State Equal Employment Opportunity Coordinator for purposes of investigation to ascertain compliance with such rules, regulations and orders. Specifically, contractors will submit workforce utilization reports to the State Equal Opportunity Coordinator by the 10th of each month.

- (7) In the event of the contractor's noncompliance with the nondiscrimination clauses of its contract or with any of the said rules, regulations, or orders, its contract may be canceled, terminated, or suspended in whole or in part and the contractor may be declared ineligible for further State Contracts or State-assisted Construction Contracts in accordance with procedures authorized in the DPW Regulations and such other sanctions may be instituted and remedies invoked, as provided in said DPW Regulations or by rule, regulation, or order of the State Equal Employment Opportunity Coordinator, or as otherwise provided by law.

In the event that its contract is terminated for a material breach of DPW Regulations, the contractor shall become liable for any and all damages which shall accrue to the State Administering Agency and Applicant and the State of Ohio as a result of said breach.

- (8) The contractor will require the inclusion of language reflecting these same eight covenants within every subcontract or purchase order it executes in the performance of its contract unless exempted by rules, regulations or orders of the State Equal Employment Opportunity Coordinator issued pursuant to O.A.C. 123:2-3-02 so that these provisions will be binding upon each subcontractor or vendor. The contractor will take such actions as the Administering Agency may direct as a means of enforcing such provisions, including sanctions for noncompliance; provided, however, that in any litigation with a subcontractor, vendor or other party as a result of such direction by the State Administering Agency, the contractor may be requested to protect the interests of the State.

>>> The prime contract bidder hereby adopts the foregoing covenants?  Yes  No

**BIDDER'S CERTIFICATION:**

The undersigned, being a duly authorized officer of the prime contract bidder, does hereby certify to and agree with the foregoing statements and covenants regarding its subscription to the State's Equal Employment Opportunity Requirements for State-assisted Construction Contracts.

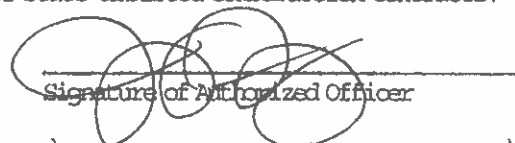
  
\_\_\_\_\_  
Signature of Authorized Officer                      Date                      5 / 23 / 24  
Joy Stang - Contract Administrator  
Title

>>> PLEASE NOTE: Only a bidder possessing a valid certificate will be awarded a contract pursuant to Chapter 153 of the Revised Code by an owner referred to in section 153.01 of the Revised Code. Application shall be made at least ten working days prior to the date that the bidder expects to receive the certificate. The bidder's failure to elect one of the two Bidder's Affirmative Action Requirements, adopt the Bidder's EEO Covenants, and complete the foregoing certification may cause the bidder's proposal to be rejected as being non-responsive to the State's Equal Employment Opportunity Requirements and in non-compliance with the State Equal Employment Opportunity Bid Conditions. In addition, the bidder must, prior to the execution of a contract, submit to the local subdivision a valid Certificate of Compliance for Equal Employment Opportunity Purposes.



December 13, 2023

Heather Thomas,  
Human Resources  
Ronyak Paving, Inc.  
14376 N. Cheshire  
Burton, OH 44021

SUBJECT: Certificate of Compliance Certification  
Status: In Compliance  
**Effective Dates:** December 13, 2023 - June 13, 2024

Dear Heather Thomas:

The Ohio Department of Development, Minority Business Development Division (MBDD) hereby issues Ronyak Paving, Inc. a Certificate of Compliance. The Certificate shall be in force for 180 days from the date of issuance.

Section 9.47 of the Revised Code requires MBDD to review affirmative action programs and plans of each company desiring to participate on state or state-assisted construction contracts and determine whether that company has violated any affirmative action programs and goals for which that company was obligated to meet during the preceding five years. Based on the above-referenced review, MBDD has found no such violation(s).

Please be advised that for Ronyak Paving, Inc. to maintain certification status, Ronyak Paving, Inc. must continue to ensure equal employment opportunities in accordance with applicable state and federal EEO laws, rules, regulations, guidelines, and meet those contractual obligations for which Ronyak Paving, Inc. has agreed.

Sincerely,

A handwritten signature in cursive script, appearing to read "Monica L. Womack".

Monica L. Womack  
Chief



Department of  
Development

Mike DeWine Governor  
Jon Husted Lt. Governor

Lydia L. Mihalik Director

June 12, 2023

Heather Thomas,  
Human Resources  
Ronyak Paving, Inc.  
14376 N. Cheshire  
Burton, OH 44021

SUBJECT: Affirmative Action Program Verification (AAPV)  
**Effective Dates:** June 12, 2023 - June 12, 2024

Dear Heather Thomas:

A business desiring to participate in the State of Ohio procurement process must demonstrate to the Ohio Department of Development, Minority Business Development Division (MBDD) that the company has complied with all applicable federal and state affirmative action programs for at least the last year.

After careful review of the provided affirmative action documentation, MBDD has determined that Ronyak Paving, Inc. satisfactorily meets the requirements set forth in Section 125.111(B) of the Ohio Revised Code as is required for participation in the State of Ohio procurement process. This letter shall serve as the State's official certification.

Please note that the MBDD may conduct an audit of Ronyak Paving, Inc. affirmative action program to determine the company's continued compliance with Section 125.111 of the Ohio Revised Code.

As the Affirmative Action Program Verification indicates, the State of Ohio values diversity among its business partners and their employees and hopes to see them grow and prosper. Consequently, MBDD was delighted to be able to assist your company by approving your affirmative action program efforts. If you need any assistance or have questions about the Affirmative Action Program Verification, its objectives, or its operation, please contact the MBDD at 614.466.8380

Sincerely,

Monica L. Womack  
Chief

# **State of Ohio**

## **Affirmative Action Program**

**TO: All Employees**  
**FROM: David Ronyak**  
**DATE: 01/01/24**  
**SUBJECT: Equal Employment Opportunity and Affirmative Action Policy Statement**

It is the policy of the Ronyak Paving, Inc. to ensure equal employment opportunity in accordance with the Ohio Revised Code 125.111 and all applicable federal regulations and guidelines. Employment discrimination against employees and applicants due to race, color, religion, sex (including sexual harassment), national origin, disability, age (40 years old or more), military status, or veteran status is illegal.

Ronyak Paving, Inc. managers and employees will comply with state and federal equal employment laws, rules, regulations and guidelines. This policy statement will be disseminated to all employees, various recruitment sources and will be displayed on all construction job sites and business locations. Any employees that deliberately violate this policy will be subject to disciplinary action.

Persons who believe Ronyak Paving, Inc. has discriminated against them may file a discrimination complaint with Heather Thomas. The EEO Representative has full authority to manage issues involving employment discrimination.

**Point of contact to file allegations of discrimination:**

Company's EEO Representative: Heather Thomas  
Location: 14376 N. Cheshire St., Burton, OH 44021  
Phone Number: (440) 834-1988  
Mail Address: [heather@ronyakpaving.com](mailto:heather@ronyakpaving.com)

# **State of Ohio Affirmative Action Program**

The purpose of the Affirmative Action sample is to provide an acceptable program which addresses employment and the effective utilization of economically disadvantaged persons. This program is not to impose numerical minimums or standards, however, adopting this program demonstrates a good faith effort to improve the equality of all citizens of the State of Ohio.

## **EEO Recruitment Strategies**

Strategy: Ronyak Paving, Inc. will make a good faith effort to recruit a diverse group of employees and provide equal opportunity for minorities, women and disabled persons to become competitive in state contracting opportunities. Ronyak Paving, Inc. will advertise positions in media outlets that will provide information and access to the underserved populations.

## **EEO Selection Strategies**

Strategy: Ronyak Paving, Inc. will utilize procedures, processes and techniques that are fair and do not have an adverse impact on minorities, women or disabled persons. Perspective employees will not be excluded from the hiring process due to race, color, religion, sex (including sexual harassment), national origin, disability, age (40 years old or more), military status, and veteran status.

## **EEO Placement/Orientation**

Strategy: Ronyak Paving, Inc. will provide newly hired employees with basic employment information during the first couple weeks on the job. New employee position descriptions, fringe benefits information, policies, procedures, and EEO are a few of the topics, which should be covered. Employees will not be denied fringe benefits and or opportunities for promotion based on race, color, religion, sex, national origin, disability, age (40 years old or more), military status and veteran status.

## **EEO Performance Evaluation**

Strategy: Ronyak Paving, Inc. will evaluate the performance of their employees on an annual basis. It should provide the necessary supervisory feedback to identify areas to be improved as well as to reinforce those activities that meet or exceed standards. Performance appraisal will be evaluated without regard to race, color, religion, sex, national origin, disability, age (40 years old or more), military status and veteran status.

## **EEO Training Strategies**

Strategy: Ronyak Paving, Inc. will attempt to diversify workforce by utilizing training and apprenticeship programs with diverse participants. Training and apprenticeship programs can increase the number of qualified minorities, women, disabled persons and veterans available for job placement.

## **EEO Discipline Strategies**

Strategy: Ronyak Paving, Inc. will set clear disciplinary standards and warn of consequences for non-compliance. Discipline will be designed to rehabilitate employees who choose to correct their behavior as well as justify the termination of those who do not. The employer will not mistreat or unfairly discipline an employee based on race, color, religion, sex, national origin, disability, age (40 years old or more), military status and veteran status.

## **EEO Separation Strategies/Exit Interviews**

Strategy: Ronyak Paving, Inc. will conduct exit interviews as a problem-solving tool in an attempt to reveal employee turnover. Exit interviews can provide the organization with information about how to correct the causes of discontent and reduce the costly problem of employee turnover.

## **EEO Monitoring Strategies**

Strategy: Ronyak Paving, Inc. will ensure Human Resources managers and supervisors understand this plan and hold managers and supervisors accountable for the effective of this plan.

## **EEO Minority Business Enterprise Certification Strategies**

Strategy: Ronyak Paving, Inc. will make a good faith effort to solicit business from certified minority owned businesses (MBE). Ronyak Paving, Inc. will utilize the State of Ohio, Equal Opportunity Division's webpage to access certified MBEs. <http://das.ohio.gov/Eod/MBESearch/index.asp>

**"APPENDIX A" OF THE STATE BEO BID CONDITIONS**

**MINORITY MANPOWER UTILIZATION GOALS AND TIMETABLES**

The following minority goals listed are expressed in terms of percentages of work hours for each trade to be used by the contractor in a designated area. Designated areas are defined as Ohio's Standard Metropolitan Statistical Areas (SMSA). They are: Akron, Cincinnati, Cleveland, Columbus, Dayton, Toledo and Youngstown-Warren. In cases where the project is not located in a designated area, the contractor may adopt minority utilization goals of the near/nearest designated area.

<b>AKRON</b>		<b>CINCINNATI</b>		<b>COLUMBUS</b>	
<u>Trade</u>		<u>Trade</u>		<u>Trade</u>	
Asbestos Workers	10.0%	Asbestos Workers	9.0%	Asbestos Workers	10.0%
Boilermakers	10.0%	Boilermakers	9.0%	Boilermakers	10.0%
Bricklayers	10.0%	Carpenters	10.0%	Bricklayers	10.0%
Electricians	10.0%	Elevator Constructors	11.0%	Carpenter	10.0%
Elevator Constructors	10.0%	Floor Layers	10.0%	Cement Mason	10.0%
Glaziers	10.0%	Glaziers	10.0%	Elevator Constructors	10.0%
Ironworkers	10.0%	Lathers	10.0%	Glaziers	10.0%
Operating Engineers	10.0%	Marble, Tile & Terrazzo		Ironworkers	10.0%
Painters	10.0%	Workers & Helpers	8.0%	Lathers	10.0%
Plasterers	10.0%	Millwrights	10.0%	Operating Engineers	10.0%
Plumbers	10.0%	Operating Engineers	11.0%	Painters	10.0%
Roofers	10.0%	Painters	11.0%	Plasterers	10.0%
Sheet Metal Workers	10.0%	Pipefitters	11.0%	Plumbers & Pipefitters	10.0%
		Plasterers	10.0%	Roofers	10.0%
		Plumbers	11.0%	Sheet Metal Workers	10.0%
		Sheet Metal Workers	11.0%	Other Trades	10.0%
		Other Trades	11.0%		
<b>CLEVELAND</b>		<b>DAYTON</b>		<b>YOUNGSTOWN - WARREN</b>	
<u>Trade</u>		<u>Trade</u>		<u>Trade</u>	
Asbestos Workers	17.0%	Asbestos Workers	11.0%	Asbestos Workers	9.0%
Boilermakers	10.0%	Boilermakers	11.0%	Bricklayers	9.0%
Carpenters	16.0%	Carpenters	11.0%	Carpenters	9.0%
Electricians	20.0%	Electricians	11.0%	Electrical Workers	9.0%
Elevator Constructors	16.0%	Elevator Constructors	11.0%	Elevator Constructors	9.0%
Glaziers	17.0%	Ironworkers	11.0%	Floor Mechanics	9.0%
Ironworkers	13.0%	Lathers	11.0%	Glaziers	9.0%
Operating Engineers	17.0%	Millwrights	11.0%	Ironworkers	9.0%
Painters	17.0%	Operating Engineers	11.0%	Lathers	9.0%
Pipefitters	17.0%	Painters	11.0%	Operating Engineers	9.0%
Plasterers	20.0%	Plumbers	11.0%	Painters & Pipefitters	
Plumbers	17.0%	Sheet Metal Workers	11.0%	& Steamfitters	9.0%
Roofers	17.0%	Other Trades	11.0%	Sheet Metal Workers	9.0%
Other Trades	17.0%			Teamsters & Chauffeurs	
				Workers	9.0%
<b>TOLEDO</b>					
<u>Trade</u>					
Asbestos Workers	9.0%	Lathers	9.0%		
Boilermakers	9.0%	Operating Engineers	9.0%		
Carpenters	9.0%	Painters	9.0%		
Electricians	9.0%	Plumbers	9.0%		
Elevator Constructors	9.0%	Sheet Metal Workers	9.0%		
Glaziers	9.0%	Other Trades	9.0%		
Ironworkers	9.0%				

**"APPENDIX B" OF THE STATE EEO BID CONDITIONS**

**SPECIFIC AFFIRMATIVE ACTION STEPS**

The following Affirmative Action steps are directed at increasing minority utilization:

- (1) The contractor should maintain a file of the names and addresses of each minority and female referred to it by any individual or organization and what action was taken with respect to each such referred individual, and if the individual was not employed by the contractor, and the reasons therefore. If such individual was sent to the union hiring hall for referral and not referred back by the union or if referred back by the union or if referred, not employed by the contractor, the file should document this and the reason therefore.

To Demonstrate Compliance: Maintain a file of the names, addresses, telephone numbers, and craft of each minority and female applicant showing (a) the date of contact and whether the person was hired; if not, the reason, (b) if the person was sent to a union for referral, and the results (c) follow-up contacts when the contractor was hiring.

- (2) The contractor should promptly notify the State Contracting Agency when the Union or Unions with which the contractor has collective bargaining agreements does not refer to the contractor a minority or female worker referred (to the union) by the contractor, or when the contractor has information that the union referral process has impeded efforts to meet its goals.

To Demonstrate Compliance: Have a copy of letters sent, or do not claim the union is impeding the contractors' efforts to comply.

- (3) The contractor should disseminate its Equal Employment Opportunity policy within its organization by including it in any company newsletters and annual reports; by advertising at reasonable intervals in union publications; by posting of the policy; by specific review of the policy with minority and female employees; and by conducting staff meetings to explain and discuss the policy.

To Demonstrate Compliance: Have a written EEO policy which includes the name and how to contact the contractor's EEO Officer and (a) include the policy in any company policy manuals, (b) post a copy of the Policy on all company bulletin boards (in the office and on all job sites), (c) records, such as reports or diaries, etc., that each minority and female employee is aware of the Policy and that it has been discussed with them, (d) that the policy has been discussed regularly at staff meetings and (3) copies of newsletters and annual reports which include the Policy.

- (4) The contractor should continually monitor all personnel activities to ensure that its EEO policy is being carried out, including the evaluation of minority and female employees for promotional opportunities on a quarterly basis and the encouragement of such employees to seek those opportunities.

To Demonstrate Compliance: Have records that the company EEO Officer reviews all: (a) monthly workforce reports, (b) hiring and terminations, (c) training provided on-the-job, (d) minority and female employees quarterly for promotion and encourages them to prepare for and seek promotion. The records should be the EEO Officer's job description, reports, memos, personnel files, etc., documenting the activities for possible discriminatory patterns.

- (5) The contractor should disseminate its EEO policy externally by informing and discussing it with all recruiting sources; by advertising it in news media, specifically including minority and female news media; and by notifying and discussing it with all subcontractors.

To Demonstrate Compliance: Have copies of (a) letters sent, at least six months or at the start of each new major contract, to all recruiting sources (including labor unions) requiring compliance with the Policy, (b) advertising, which has the EEO "tagline" on the bottom, and (c) purchase order and subcontract agreement forms will include or make reference to the State EEO Covenant, Appendix A or B of the Ohio Administrative Code 123:2-3-02.

- (6) The contractor should make specific and reasonably recurrent oral and written recruitment efforts directed at minority and women's organizations, and training organizations with the contractor's recruitment area.

To Demonstrate Compliance: Have a record either in a follow-up file for each organization or on the reverse of the notification letter sent under Item 1, above, of the dates, individuals contacted and the results of the contract from telephone calls or personal meetings with the individuals or groups notified under Item 1.

- (7) The contractor, where reasonable, should develop on-the-job training opportunities and participate and assist in all Department of Labor funded and/or approved training programs (including Apprenticeship) Programs relevant to the contractor's employee needs consistent with its obligations in the Bid Conditions.

To Demonstrate Compliance: Have records of contributions in cash, equipment supplied and/or contractor personnel provided as instructors for Bureau of Apprenticeship and Training approved or Department of Labor funded training programs and records of the hiring and training of minorities and females referred to Company by such programs.

- (8) The contractor should solicit bids for subcontracts (and joint ventures) from available minority and female subcontractors engaged in the trades covered by the Bid Conditions, including circulation of minority and female contractors associations.

To Demonstrate Compliance: Have copies of letters or other direct solicitation of bids for subcontracts/joint ventures from minority/female contractors with a record of the specific response and any follow-up the contractor has done to obtain a price quotation or to assist a minority/female contractor in preparing or reducing a price quotation; have a list of all minority/female subcontracts awarded or joint ventures participated in with dollar amounts, etc.

#### **EXPLANATION OF AN ACCEPTABLE AFFIRMATIVE ACTION PROGRAM:**

An Affirmative Action Program is a set of specific and result-oriented procedures to which a Contractor shall apply every good faith effort. The objective of those procedures and efforts is to assure equal employment opportunity. An acceptable Affirmative Action Program will include an analysis of all trades employed by the Contractor within the last year with an explanation of whether Minorities are currently being under-utilized in any one or more trades. A necessary prerequisite to the development of a satisfactory Affirmative Action Program is the identification and analysis of problem areas inherent in Minority employment and an evaluation of opportunities for utilization of Minority group personnel.

Part I - Basic Contents of an Affirmative Action Program:

1. Development or reaffirmation of the contractor's EEO policy in all personnel actions.
2. Formal internal and external dissemination of contractor's EEO policy.
3. Establishment of responsibilities for implementation of the contractor's affirmative action program.
4. Identification of problem areas (deficiencies) by organizational units and job classification.
5. Establishment of goals and objectives by organizational units and job classification, including timetables for completion.
6. Development and execution of action oriented programs designed to eliminate problems and further designed to attain established goals and objectives.
7. Design and implementation of internal audit and reporting systems to measure effectiveness of the total programs.
8. Compliance of personnel policies and practices with Federal sex discrimination guidelines (41 CFR Part 60-20).
9. Active support of local and national community action programs and community service programs, designed to improve the employment opportunities of minorities.
10. Consideration of ethnic minorities and women not currently in the work force having requisite skills who can be recruited through affirmative action measures.
11. Summary data on applicant flow, hires, terminations and promotions, and training for the last twelve months or the last one hundred applicants, hires, etc., whichever is less.

Part II - Analysis of Individual Trades

1. The minority population of the labor area surrounding (contractor's) projects.
2. The size of the minority unemployment force in the labor area surrounding (the contractor's) projects.
3. The percentage of minority work force as compared with the total work force in the immediate labor area.
4. The general availability of minorities having requisite skills in the immediate labor area.
5. The availability of minorities having requisite skills in the area in which the contractor can reasonably recruit.

6. The availability of promotable minority employees within the contractor's organization.
7. The anticipated expansion, contraction, and turnover of an in the work force.
8. The existence of training institutions capable of training minorities in the requisite skills.
9. The degree of training which the contractor is reasonably able to undertake as a means of making all job classes available to minorities.

Goals, timetables and affirmative action commitments must be designed to correct any identifiable deficiencies. Where deficiencies exist and where numbers or percentages are relevant in developing corrective action, the contractor shall establish and set forth specific goals and timetables. Such goals and timetables, with supporting data and the analysis thereof shall be a part of the contractor's written affirmative action program. Where the contractor has not established a goal, its written affirmative action program must specifically analyze each of the factors listed above, and must detail its reason for a lack of a goal. The goals and timetables should be attainable in terms of the contractor's analysis of its deficiencies and its entire action. Thus, in establishing its goals and timetables, the contractor should consider the results which could be reasonably expected from its good faith efforts to make its overall affirmative action program work. If the contractor does not meet its goals and timetables, the contractor's good faith efforts shall be judged as to whether the contractor is following its program and attempting to make the program work toward the attainment of its goals.

Support data for the above analysis and program shall be compiled and maintained as part of the contractor's affirmative action program. This data should include applicant flow data and applicant rejection ratios indicating minority status.

Compliance Status: No State Contractor's compliance status shall be judged alone by whether or not he reaches his goals and meets his timetables. Rather each Contractor's compliance posture shall be reviewed and determined by reviewing the contents of his program, the extent of his adherence to his program and his good faith efforts to make his program work toward the realization of the program's goals within the timetables set for completion.

**"APPENDIX C" OF THE STATE EEO BID CONDITIONS**

**FEMALE UTILIZATION GOALS - GOVERNOR'S AMENDED EXECUTIVE ORDER 84-9**

Governor's Amended Executive Order 84-9 regarding women in the construction labor force, went into effect November 30, 1984. To be in compliance with this order, all contractors and all subcontractors must meet or exceed the goal of six and nine-tenths percent (6.9%) female utilization. This percentage of female utilization is expressed in terms of female hours of training and employment as a proportion of the total hours to be worked by the contractor's entire workforce in each craft or trade on all projects, both state and non-state, in the State of Ohio during the performance of its State-assisted contract.

No contractor's compliance shall be judged alone by whether or not goals and timetables are met. Rather, each contractor's compliance posture shall be reviewed and determined by examining the contents of the contractor's affirmative action plan or the contract compliance with the state's affirmative action plan and its good faith efforts to implement such program to meet the goals established.

Reporting shall be done by the contractor on Input Form 29, Ohio Construction Information Reporting System, and submitting it to the State Equal Employment Opportunity Coordinator. Further questions concerning this should be addressed to the State Equal Opportunity Coordinator, 77 South High Street, 24th Floor, Columbus, OH 43266-0408. Phone: (614) 466-8380.

## **I. INSTRUCTIONS TO BIDDERS**

### **1. SUBMISSION OF BID**

Sealed Bids will be received at the County Engineer's Office, on or before the advertised Bid date and time, as extended, for all labor, materials, equipment, supervision, coordination and other things necessary for the full and complete performance of the project described by the accompanying Bid advertisement (herein referenced as the "Project").

Bids must be submitted in sealed envelopes marked with the Quotation Number. Bids shall be opened immediately upon expiration of the Bid submission time, with the names of bidders and their respective bid prices read publicly.

### **2. STANDARD SPECIFICATIONS & TERMS**

The Construction & Material Specifications of the State of Ohio, Department of Transportation (latest edition as of the date of advertisement), excluding only sections 102 and 103 titled "Bidding" and "Award", shall serve as standard specifications for any contract awarded hereunder. Said Construction & Material Specifications are referenced herein as the "Standard Specifications." Supplemental specifications, requirements, terms, conditions and covenants of these Instructions to Bidders and of the accompanying Bid Documents shall control over conflicting terms found in the Standard Specifications.

Wherever the following terms appear in the Standard Specifications, said terms shall have the following meaning:

- A. The terms "State", "State of Ohio", "Department" and "Department of Transportation" refer to the County, acting through its Board of County Commissioners. The County also may be referenced as the "County" or the "Owner" herein.
- B. The term "Director," "DCE" and "DDD" refers to the County Engineer.
- C. The term "Engineer" refers to the County Engineer, or to his duly authorized representative.
- D. The term "Laboratory" refers to such testing laboratory or consultant as shall be designated by the County Engineer, or by the County Engineer's duly authorized representative.

A numerical designation for an "item" referenced herein refers to the description of said item number as provided by the Standard Specifications.

Bidders are specifically referred to the definitions provided by section 101.03 of the Standard Specifications. Any undefined trade and technical words and terms shall be deemed to have the meaning established by trade usage in the highway/bridge construction and civil engineering consultation business.

### **3. FORM OF BID**

Bids shall be submitted using the attached blank forms, designed for such purpose. These forms must be completed intact, without removal of any part, must recite the full name of the party making the Bid, and must be properly signed.

In each blank marked "unit price", bidders are required to provide a Bid price per referenced unit for the requested materials, labor or equipment, or referenced combination thereof. Failure to provide a price for each unit price item, or failure to provide prices for lump sum items, will render the Bid informal, allowing its rejection at the County's discretion.

Extended unit prices are calculated by multiplying the bidder's unit price entries times their respective approximate quantities. The resultant extended unit price figures, in addition to any lump sum prices, are added to calculate the amount of each Bid.

The sum of the extended unit prices and lump sum prices provided by each Bidder shall comprise that Bidder's Bid price for consideration of award of contract. If an error is made in the extension of unit prices, or in the addition of the extended unit and lump sum prices, the accurate extended unit prices and total shall govern.

Quantities provided by the Bid Documents are estimates only. The County reserves the right to eliminate, increase or decrease the actual quantity of any unit price item, or to non-perform any lump sum item.

### **4. BIDDER QUALIFICATIONS**

Bidders must be prequalified. Prequalification by the Ohio Department of Transportation, as described by ORC sections 5525.02-.09, for performance of Work of the same type, character and magnitude as described hereby, is acceptable.

### **5. EXAMINATION OF BID DOCUMENTS & SITE OF WORK**

Bidders must carefully examine the Bid Documents and perform a reasonable site investigation before submitting a Bid. Submission of a Bid is an affirmative statement that the Bidder has investigated the Project site and is satisfied as to the character, quality, quantities and conditions to be encountered in performing the Work. A reasonable site investigation includes investigating the Project site, borrow sites, hauling roads and all other locations related to the performance of the Work.

ODOT  
Pre-Qualified Contractors

Enter Contractor to search on

RONYAK PAVING INC

Toggle Work Types

Select Work Types

- 1. Clearing and Grubbing
- 2. Building Removal
- 3. Gas, Oil, Water Well Abandonments
- 4. Roadway Excavation and Embankment Construction
- 5. Major Roadway Excavation
- 6. Incidental Grading
- 7. Soil Stabilization
- 8. Temporary Soil Erosion & Sediment Control

Control

- 9. Aggregate Bases
- 10. Flexible Paving
- 11. Apply Bituminous Treatments
- 12. Rigid Paving
- 13. Pavement Planing, Milling, Scarification
- 14. Concrete Texturing
- 15. Sawing
- 16. Flexible Replacement
- 17. Rigid Pavement Replacement
- 18. Pavement Rubblizing, Breaking, Pulverizing
- 19. Structure Removal
- 20. Level 1 Bridge

ACCOUNT NAME	VENDOR ID	ADDRESS	APP EXP DATE	WORK TYPES
RONYAK PAVING INC	121815008	14376 N CHESHIRE ST BURTON OH, 44021 440-834-1988	2024-05-31	1. Clearing and Grubbing 4. Roadway Excavation and Embankment Construction 6. Incidental Grading 8. Temporary Soil Erosion & Sediment Control 9. Aggregate Bases 10. Flexible Paving 11. Apply Bituminous Treatments 13. Pavement Planing, Milling, Scarification 15. Sawing 16. Flexible Replacement 17. Rigid Pavement Replacement 19. Structure Removal 35. Drainage (culvert, misc.) 38. Miscellaneous Concrete 39. Maintenance of Traffic 40. Waterproofing 46. Landscaping 48. Trucking

## 6. BID GUARANTEE

Each Bid shall be accompanied by a bid guarantee, in the form of a bid bond, a certified check, a cashiers check or a letter of credit, in conformity with the requirements of ORC 153.54 and 153.571 (B). If a bid bond is used, the bond shall be in the full amount of the bid and signed by a Surety company authorized to do business in Ohio, and accompanied by the Surety's sufficient power of attorney affirming said signature. If a certified check, cashiers check or letter of credit is used, the instrument shall be drawn on a solvent bank in an amount not less than ten percent (10%) of the Bid. The bid guarantee shall be given as security that, if the Bid is accepted, the Bidder will enter into a contract in conformity with the Bid. Bids less than twenty-five thousand dollars (\$25,000.00) do not require a bid guarantee.

## 7. FACTORS FOR ACCEPTANCE OR REJECTION OF BIDS

- A. Pursuant to ORC 307.90 (A), a contract shall be awarded to the lowest and best Bid.
- B. Any Bid which is incomplete, conditional, obscure, or which contains additions not called for or irregularities of any kind, may be rejected.
- C. The County reserves the right to reject any and all Bids, and also the right to waive any informality in the Bid. The County has the right to postpone the decision to award a contract for up to sixty (60) days.
- D. No contract shall be awarded to any person, firm, or corporation that is in arrears or is in default to the County upon any debt or contract, or that is in default as surety or otherwise upon any obligation to the County, or has failed to perform faithfully any previous contract with the County, or that has an unresolved finding of recovery with the State Auditor, or has been debarred by the County from consideration for contract awards .
- E. R.C. §3517.13(I)(3) and R.C. § 3517.13(J)(3) require that no political subdivision shall enter into any contract for the purchase of goods or services costing more than ten thousand dollars with a corporation, individual, partnership, other unincorporated business, association, including without limitation, a professional association organized under Chapter 1785 of the revised code, estate or trust unless the contract includes a certification that the individuals named in R.C. §3517.13(I)(3) and R.C. § 3517.13(J)(3) are in compliance with the aforementioned provisions. The offeror is required to complete the (2) affidavits contained herein and submit same with their proposal/bid. **Failure to submit the required forms with the proposal/bid packet will deem the offeror's response to be non-responsive and disqualified from receiving further considerations.**

## 8. WITHDRAWAL OF BIDS

A Bidder may request, in writing, to withdraw its Bid within five business days of the opening. Such requests will be reviewed by the County for approval as permitted by ORC 9.31 and 153.54 (G). If approved, collection of the bid guarantee or bond will be waived.

## **9. DOMESTIC USE REQUIREMENTS; LOAD BEARING STRUCTURAL STEEL**

Domestic steel use requirements as specified in Section 153.011 of the Ohio Revised Code apply to this project. Copies of Section 153.011 of the Revised Code can be obtained from any of the offices of the State of Ohio Department of Administrative Services.

## **10. PREVAILING WAGE RATES**

All employees on the Work site shall be paid at the prevailing wage rate for the appropriate class of Work. The prevailing wage rates shall be determined in accordance with ORC Chapter 4115, except for employees who are covered by a collective bargaining agreement in existence prior to the date of contract, who shall be paid the rate of pay provided by such agreements. Schedules of applicable prevailing wage rates are attached to the Specifications. Bidders are cautioned to assure the completeness of said wage schedules, and to notify the County Engineer prior to the bid date of any omitted schedules.

## **11. OTHER COSTS & REQUIREMENTS**

Bids must include all costs of performing the Work and all costs of fulfilling the requirements of laws, rules and regulations pertaining thereto. The following is a partial list of ancillary contract costs and requirements. Said list is provided for the convenience of Bidders, to assist in their inclusion of all components of costs and fulfillment of all requirements, though this list does not recite all such costs and requirements.

- A. Bids must include the cost of all required bonds (performance and maintenance).
- B. Bids must include the cost to procure all permits and licenses, to pay all charges, fees and taxes, and to provide all notices necessary and incidental to the due and lawful prosecution of the Work.
- C. Bids must include the cost of insurance coverage of the type and at least in the amounts set forth by section 107.12 of the Standard Specifications and by any special bid provisions.
- D. The County is exempt from all sales, excise, and transportation taxes, with the exception of State of Ohio gasoline tax. Bid prices shall exclude all such taxes.
- E. "Declaration of Personal Property Tax Delinquency" form must be fully executed and notarized pursuant to ORC section 5719.042, before an award can be made.
- F. Pursuant to ORC 3517.13(I)(3) & (J)(3), Bidders must complete the attached Contributions Limitations Certification.

**II. SUPPLEMENTAL INSTRUCTIONS TO BIDDERS**

**1. BIDDER PREFERENCES**

N/A

**2. ADDITIONAL BIDDER QUALIFICATION REQUIREMENTS**

1

**3. OTHER SUPPLEMENTAL INSTRUCTIONS TO BIDDERS**

N/A

### **III. SUPPLEMENTAL CONTRACT PROVISIONS**

#### **1. AWARD REQUIREMENTS OF SUCCESSFUL BIDDER / CONTRACTOR**

The following is a partial list of award of contract requirements. Said list is provided for the convenience of Bidders, to assist in their inclusion of all components of costs of such requirements, though this list does not recite all such costs and requirements.

- A. The successful Bidder/Contractor must provide a one hundred percent (100%) Performance Bond based on the contract amount, in conformity with the requirements of ORC section 153.54 (C) and 153.57 (A). A Maintenance Bond in the amount of ten percent (10%) of the final contract amount, extending coverage for one (1) year beyond the acceptance date of the completed Project, must be provided by the Contractor as a prerequisite to final payment. Said Maintenance Bond shall assure the repair and/or correction of any defects, deficiencies or omissions in the Project Work.
- B. The Contractor must provide evidence of all insurance coverage requirements of section 107.12 of the Standard Specifications.
- C. The Contractor agrees to provide the County with full and complete documentation of payment of prevailing wages to all employees of the Contractor and of its subcontractors governed by Prevailing Wage law.
- D. The Contractor agrees to provide the County with a contact person, a telephone number, a mailing address and, if available, an electronic mail address for purposes of giving notice to the Contractor of any changes in prevailing wage rates. Where an electronic mail address is given, the Contractor agrees that the use of that method by the County satisfies any notice requirements of any change in prevailing wage rates. Upon commencement of contract work, the Contractor and its subcontractors subject to the contract's prevailing wage requirements must provide the prevailing wage coordinator with a schedule of wages, with certified copies of payroll being required throughout work on the Project.
- E. The Contractor further agrees to stay informed of applicable prevailing wage rates and to immediately inform all its subcontractors and the Engineer of such changes. The Contractor agrees to defend and indemnify the County, its elected officials, agents and employees, against all claims, actions, demands, judgments, settlements, damages, liabilities, losses, and costs of any kind, including, but not limited to, reasonable fees of attorneys and experts, arising from or related to the Contractor's failure to inform its subcontractors of changes in prevailing wage rates.
- F. The Contractor must furnish the County with a completed IRS form W-9, "Request for Taxpayer Identification Number & Certification." The Internal Revenue Code requires the County to file an information return each January 31<sup>st</sup> on all payments made the previous year of \$600.00 or more. As required by Section 3406 of the Internal Revenue

Code (26 U.S.C. 3406), the County shall withhold federal taxes at a rate of thirty-one percent (31%) if a correct taxpayer identification number is not provided. Back-up withholding requirements continue until the required information is received.

## **2. OTHER CONTRACTOR DUTIES**

In addition to the duties cited by the Standard Specifications and elsewhere in these Bid Documents, the Contractor has the following duties:

- A. When determined necessary by the Engineer, the Contractor shall provide a field office, suitably located and of ample size and accommodations, from which the Engineer's inspections, as well as the Contractor's Work, may be carried out. The Contractor must keep a full set of Plans and Specifications available at the field office.
- B. The Contractor must furnish, without extra compensation therefore, such assistance as the Engineer, or his assistants or inspectors may require, in measuring in and setting stakes or marks for indicating lines, grades or levels, for measuring or determining quantities for estimates, and for handling and inspecting materials to be used on the Work, whether such materials have been delivered upon the site of the Work or are in local storage. The Contractor shall provide such facilities for weighing and measuring materials as the Engineer may deem necessary, to secure the proper fulfillment of the provisions and requirements of the Specifications.
- C. The Contractor shall diligently protect and preserve all stakes, marks, bench marks and monuments set or used by the Engineer, and shall be responsible for securing therefrom the proper lines, grades and levels for the structures to be built.
- D. The Contractor must place or construct, in such manner and at such points as the Engineer may require, necessary sanitary conveniences for the use of employees on the Work site. They shall be properly secluded from public observation, shall be maintained sanitary and inoffensive at all times, and their use shall be strictly enforced. The Contractor must provide an ample supply of pure drinking water for employees at all times, and the source of such supply shall be subject, at all times, to the approval of the Engineer.
- E. The Contractor is reminded of its duty to notify the registered underground utility protection service and owners of underground utility facilities at least two working days in advance of commencement of construction operations that may involve such facilities, to allow surface marking of facility locations.

## **3. DISCRIMINATION PROHIBITED**

The Contractor understands and agrees that, in the hiring of employees for the performance of work under the contract or any subordinate contract thereunder, the Contractor, its subcontractors and persons acting on behalf of the same shall not discriminate in the hiring or retention of

subordinate contractors or employees "by" or "for" reason of race, creed, sex, disability (as defined by ORC 4112.01) or color; nor shall said parties discriminate against any citizen of the State of Ohio in the employment of labor or workers who otherwise qualify and who are available to perform the work to which the contract relates.

Further, the Contractor and its subcontractors and persons acting on behalf of the same shall not discriminate against or intimidate any employee hired for performance of the Work under the contract on account of race, creed, sex, disability (as defined by ORC 4112.01) or color.

In addition, the Contractor agrees, as a prerequisite of award, to complete the attached "Equal Employment Opportunity Compliance Certificate," and to fulfill all requirements thereof.

#### **4. INSPECTION**

The Engineer, assistants and agents, shall have, at all times, immediate access and right to enter upon the Work site and other Work premises occupied by the Contractor as well as upon the site of all sources from which materials are being obtained for the contract. The Contractor shall provide safe and proper facilities for permitting such entrance and for inspecting and testing purposes. Subcontractors and suppliers shall have similar obligations imposed by subordinate contracts. The Contractor shall furnish the Engineer with all reasonable facilities for ascertaining that the materials and Work are in accordance with the requirement and intention of the Specifications and contract, even to the extent of uncovering or removing portions of finished Work.

The Contractor shall give definite information, at any time, as to the place from which, or persons from whom, any material is being or will be procured. All materials to be used may be subjected to such tests as the Engineer may require to assure that such materials conform, in all respects, to the requirements of the Specifications, or that they are equal in quality to samples submitted by the Contractor. All materials which do not conform to such requirements shall be rejected, and the Contractor shall remove such rejected materials from the vicinity of the Work within twenty-four (24) hours thereafter.

The inspection and supervision of the Work and materials by the Engineer, assistants and inspectors, is intended to aid the Contractor in accomplishing the fulfillment of duties and obligations under the contract, but such inspection and supervision shall not relieve the Contractor from contract obligations.

Defective Work shall be made good and unsuitable materials may be rejected, notwithstanding that such Work and materials have been previously overlooked by the Engineer and accepted or estimated for payment. If the Work, or any part thereof, is found, at any time before the acceptance of the whole Work and for the period of the Maintenance Bond thereafter, to be defective, or to contain defective materials, the Contractor shall make good such defects under the direction of the Engineer.

Upon being attached to, or incorporated in the Work, or affixed in or to the soil, all materials shall become the property of the County. Thereafter the Contractor shall have no right of property therein, unless they are afterward rejected by the Engineer. The Contractor bears risk of loss of and damage to the Work until completion and final acceptance of the Work.

The Contractor shall schedule inspection 24 hours in advance of the performance of the respective Work. At the pre-construction meeting, the Engineer shall provide the Contractor with phone numbers and names of a contact person and of the Engineer's inspectors. The Contractor shall inform the Engineer of his Work schedule and the hours that Work will be performed. The Engineer shall approve the Contractor's schedule and hours of operation before the Contractor may begin Work.

When Work is scheduled and the Contractor desires to change the approved schedule, the Contractor shall contact the Engineer's inspector at or before 7:30 a.m. of the scheduled Work date to cancel or adjust the hours of inspection. If the Contractor fails to contact the Engineer's inspector as stated above or if the notice is within two (2) hours of the scheduled inspection and is insufficient to cancel attendance by the Engineer's inspector, the Contractor will be charged for two (2) hours of inspection time at the current inspection rate. This cost will be subtracted from the Contractor's monthly pay estimate.

## **5. CHANGES IN QUANTITY OF WORK**

The quantities of Work, as given in the Estimated Quantities, are approximations only. The County Engineer shall have the power to alter by increasing, decreasing or deleting the quantities of Work to be done, either before or after the commencement of construction.

If such change involves the reduction or omission of any material or Work called for by the original Plans or Specifications, there shall be no right with the Contractor for any claims for losses or damages, or for loss of profit, growing out of such omission. If any such change involves additional material or labor, upon which the price is fixed in the Contract, that price shall govern. Any such change shall in no way relieve the Contractor of or affect any of the obligations hereunder. In like manner the County may, without affecting the contract, require the Contractor to furnish materials or to do Work for which no price is given as provided by the Standard Specifications.

If such changes result in increased or diminished expense of Work items, the prices of which are fixed in the contract, the County shall determine an equitable adjustment of such prices, which shall be final and binding on the parties hereto, subject to dispute resolution.

## **6. NO WAIVER OF RIGHTS**

No act of the County, or its assistants or inspectors, shall operate as a waiver of any provisions of the contract, nor shall any breach of this contract operate as a waiver of any other subsequent breach. Any and all remedies provided in this contract are cumulative, in addition to other remedies herein provided. The mention of any specific liability or duty of the Contractor, in any

part of the Specifications or contract, shall not be construed as a limitation or restriction upon general liability or duty imposed upon the Contractor by said Specifications and contract. Should any part of the Work be sublet by the Contractor, such action shall in no way release the Contractor from liability or obligation hereunder. The Contractor shall be liable for the acts, omissions and negligence of any subcontractor, and shall be responsible therefore as though no subcontract existed.

#### **7. DAMAGES FOR LATE COMPLETION; EXTENSIONS OF TIME**

Time is of the essence to this contract. The rate of progress shall be such as to complete the Project Work within the time limit specified herein.

In the event that the Work is not completed within the time limit aforesaid, the Contractor shall reimburse the County an amount equal to the County's costs for and expenses of Project inspections, supervision and similar engineering services provided by or for the County after the expiration of the aforesaid time limit, and until completion and acceptance of the Work.

In addition, in the event that the Work is not substantially completed within the time limit aforesaid, with said incompleteness prohibiting beneficial use and occupancy of the Project, in compensation for the public's loss of use of the Project, the Contractor shall forfeit liquidated damages in the amount set forth by section 108.07 of the Standard Specifications.

Such amounts shall be deducted by the Engineer from the partial or final estimates to be allowed the Contractor.

The Board of County Commissioners may for good cause shown, extend the time of completion. Any such extension of time shall not be deemed a waiver by the County of any other rights provided for under this contract, and shall not operate to release any Surety from any of bond obligations.

#### **8. NIGHT & SUNDAY WORK**

No Work requiring the presence of the Engineer's inspectors will be permitted at night or on Sunday, except in a case of an emergency, and then only to such an extent as is absolutely necessary and by written permission of the Engineer. This clause shall not prohibit the performance of Work by workmen organized for the regular continuous night work and working on only such Work as the Engineer believes may be performed satisfactorily at night.

#### **9. OTHER SUPPLEMENTAL CONTRACT PROVISIONS**

N / A

## **IV. SCOPE OF WORK**

### **1. GENERALLY**

The Contractor shall furnish, at its own cost and expense, all management, labor, tools, forms, equipment, appliances, machinery, transportation, materials and other things necessary, of whatever nature, to perform the Work, and shall perform and complete, within the time limit specified, all of the Work indicated or implied by including the Notice to Bidders, Instructions to Bidders, General & Supplemental Provisions, Standard Specifications, Scope of Work, Plans & Specifications, and Estimated Quantities prepared for this Project, including the removal of surplus or condemned materials, and the thorough cleaning of the site of the Work and structures built.

In no case will any Work, in excess of such requirements, be paid for unless ordered in writing by the County as hereinafter specified.

All Work shall be of the best quality throughout. Unless otherwise provided herein, all materials shall be new.

### **2. SCHEDULE OF PERFORMANCE**

At the pre-construction meeting, the Contractor must provide the Engineer with a printed schedule showing the interrelation and planned performance of all major items of Work, with completion reasonably scheduled thereon to occur by the scheduled completion date recited herein. The Engineer shall review and consider acceptance of the schedule as provided by section 108.02 (B)(1) of the Standard Specifications.

### **3. DESCRIPTION OF SCOPE OF WORK**

Footville Richmond Road Cracking & Seating Concrete Pavement & Asphalt Paving

## **V. PLANS & SPECIFICATIONS**

### **1. GENERALLY**

The Plans and Specifications are intended to explain and supplement each other, and to indicate and provide for the construction of the various related parts of the Project in a complete and connected manner. Should any detail be omitted, any discrepancies or errors appear, or misunderstandings arise, in or with respect to such Plans and Specifications, the additions, corrections, or explanations necessary to provide for the construction in accordance with such intent shall be made by the Engineer, and such additions, corrections and explanations shall be final and binding upon the Contractor, subject to dispute resolution.

### **2. "OR EQUAL"**

Whenever an article, material, or equipment, is defined herein by describing a proprietary product, or by using the name of manufacturer or vendor, the term "or equal", if not inserted, shall be implied. The specific article, material, or equipment mentioned, shall be understood as indicating the type, function, minimum standard of design, efficiency, and quality desired, and shall not be construed in such a manner as to exclude manufacturer's products of comparable quality, design and efficiency. The Contractor shall comply with the requirements of the contract documents, relative to the approval of materials and equipment by the County, before the same are incorporated in the Work.

### **3. LIST OF PLANS & SPECIFICATIONS**

See Attached

## **VI. PREVAILING WAGE RATE SCHEDULES**

See Attached

# FOOTVILLE RICHMOND ROAD

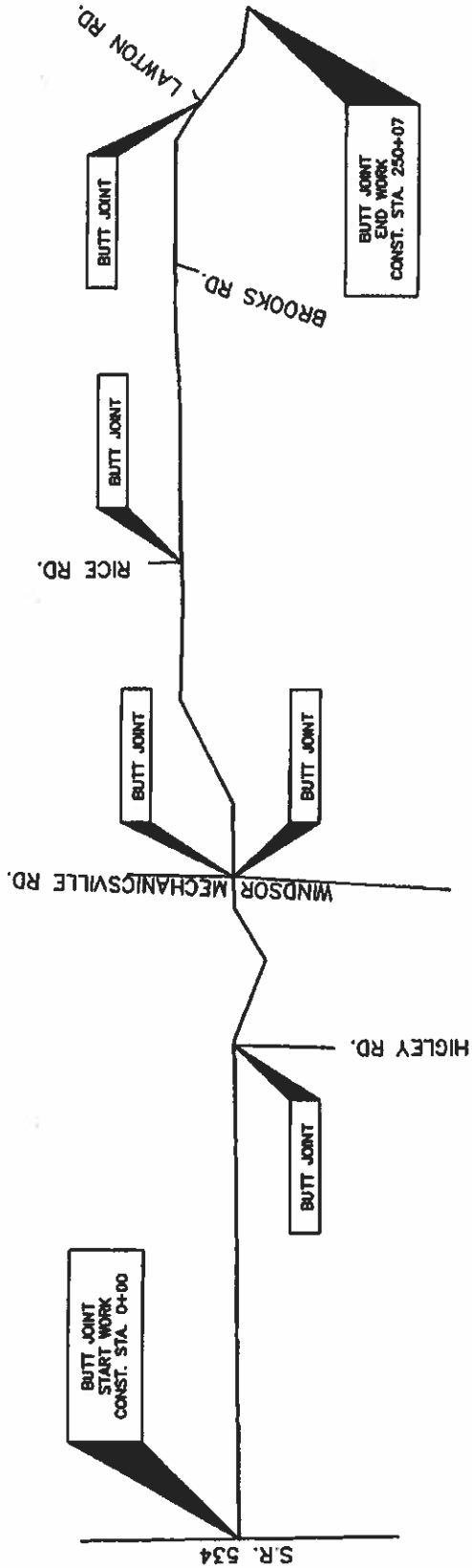

**NOTE:**

- 1.) WORK TO BEGIN AT EDGE OF PAVEMENT OF SR 534. CONST. STA. 0+00
- 2.) WORK TO END 87' EAST OF THE ROCK CREEK VILLAGE LIMITS. CONST. STA. 250+07
- 3.) WIDTH VARIES FROM 22' FOR TANGENT ROAD AND 24' FOR CURVED SECTIONS OF ROAD.

1  
11

ASHTABULA COUNTY ENGINEERING  
DEPARTMENT  
TIMOTHY T. MARTIN-COUNTY ENGINEER

PAVING PLAN  
FOOTVILLE RICHMOND ROAD C.H. SEC D-H

SCALE:

DRAWN: K.A.S  
DATE: 4/12/24  
REVISION:



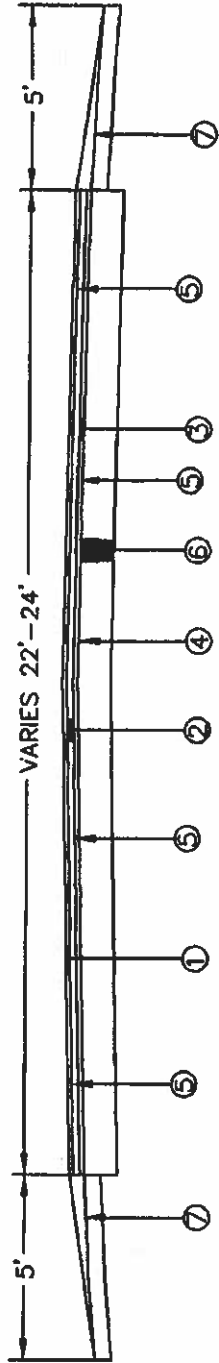

PROPOSED TYPICAL SECTION

APPLIES: SR 534 TO ROCK CREEK VILLAGE LIMITS. 25,000'

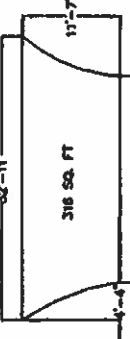

- ① ITEM 441 1.5" ASPHALT CONCRETE SURFACE COURSE, TYPE 1, (448) PG(64-22)
- ② ITEM 441 2" ASPHALT CONCRETE INTERMEDIATE COURSE, TYPE 2, (448) PG(64-22)
- ③ ITEM 441 1" ASPHALT CONCRETE INTERMEDIATE COURSE (SCRATCH), TYPE 1, (448) PG(64-22)
- ④ ITEM 422 SINGLE CHIP SEAL, TYPE A
- ⑤ ITEM 407 TACK COAT
- ⑥ ITEM 321 CRACKING AND SEATING NON-REINFORCED CONCRETE PAVEMENT
- ⑦ ITEM 617 SHOULDER RESTORATION (BY COUNTY)

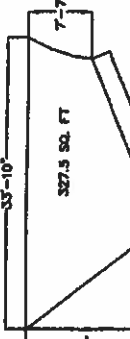
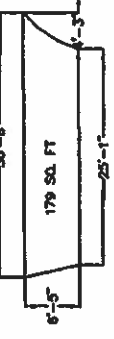
2 11	ASHTABULA COUNTY ENGINEERING DEPARTMENT TIMOTHY I. MARTIN-COUNTY ENGINEER	TYPICAL SECTION	SCALE:	DRAWN: K.A.S
		FOOTMILLE RICHMOND ROAD C.H. SEC D-H	DATE: 4/12/24	REVISION:

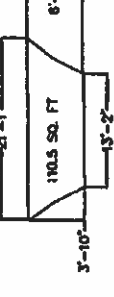
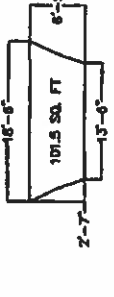
 <p>187.5 SQ. FT</p> <p>27'-6"</p> <p>109'-1"</p> <p>12'-1"</p> <p>7'-11"</p> <p>CONS. STA. 9+26 RT.</p>	 <p>316 SQ. FT</p> <p>32'-11"</p> <p>117'-7"</p> <p>8'-4"</p> <p>CONS. STA. 13+72 RT.</p>	 <p>298 SQ. FT</p> <p>36'-0"</p> <p>9'-11"</p> <p>16'-5"</p> <p>CONS. STA. 17+06 RT.</p>	 <p>327.5 SQ. FT</p> <p>33'-10"</p> <p>21'-8"</p> <p>15'-8"</p> <p>7'-7"</p> <p>CONS. STA. 18+6 7RT.</p>
 <p>179 SQ. FT</p> <p>30'-6"</p> <p>25'-1"</p> <p>6'-3"</p> <p>CONS. STA. 19+56 RT.</p>	 <p>127.5 SQ. FT</p> <p>20'-4"</p> <p>7'-3"</p> <p>14'-1"</p> <p>4'-6"</p> <p>CONS. STA. 21+10 RT.</p>	 <p>110.5 SQ. FT</p> <p>21'-1"</p> <p>6'-7"</p> <p>13'-2"</p> <p>3'-10"</p> <p>CONS. STA. 23+10 RT.</p>	 <p>101.5 SQ. FT</p> <p>16'-6"</p> <p>6'-5"</p> <p>13'-9"</p> <p>2'-7"</p> <p>CONS. STA. 23+87 RT.</p>
<p>10 CONCRETE DRIVES, WIDTHS VARY = 2,042 Sq. Ft.</p> <p>Item 452 Concrete Driveways 2,042 Sq. Ft 2,042 / 9 = 227 Sq. Yds.</p>			
<p>ASHTABULA COUNTY ENGINEERING DEPARTMENT TIMOTHY T. MARTIN-COUNTY ENGINEER</p>		<p>CONCRETE DRIVEWAY DETAILS FOOTVILLE RICHMOND ROAD C.H. SEC D-H</p>	
<p>SCALE: DATE: 4/12/24</p>		<p>DRAWN: K.A.S REVISION:</p>	

ITEM 452 6" NON-REINFORCED PORTLAND CEMENT CONCRETE PAVEMENT, (DRIVEWAYS)

3  
11

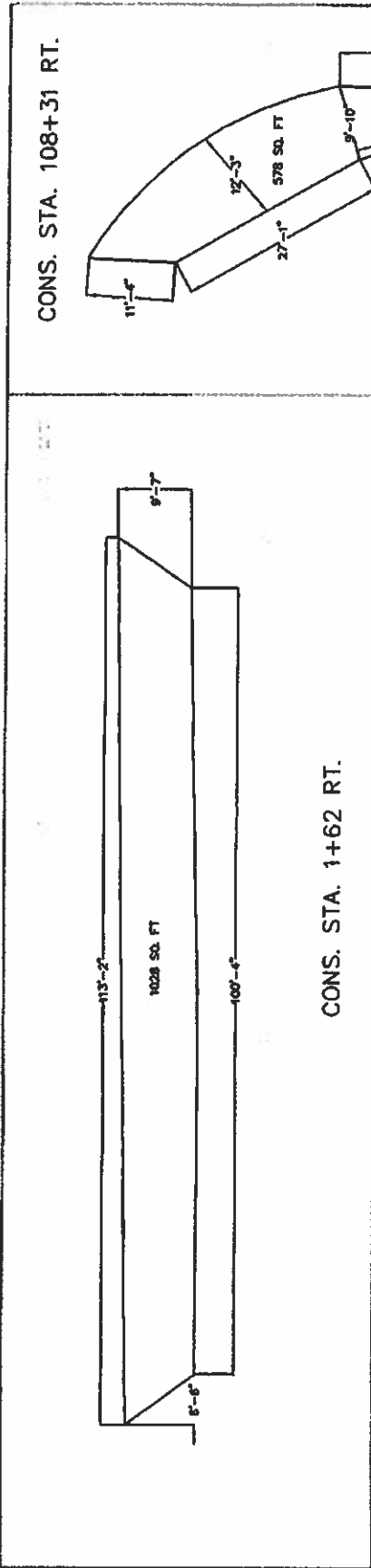

CONS. STA. 1+62 RT.

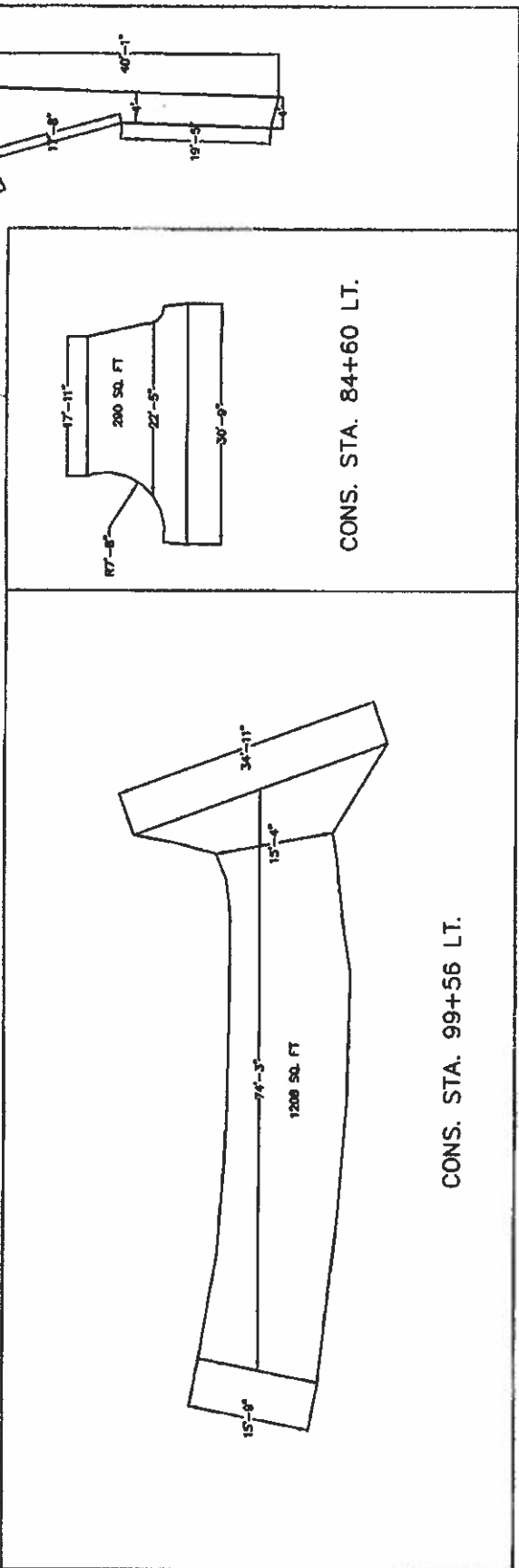

CONS. STA. 99+56 LT.

4 ASPHALT DRIVES, WIDTHS VARY = 3,110 Sq. Ft.

ITEM 441 2" ASPHALT CONCRETE SURFACE COURSE, (449) (DRIVEWAYS)

Item 441 Asphalt Driveways  
3,110 Sq. Ft  
3,110 / 9 = 346 Sq. Yds.

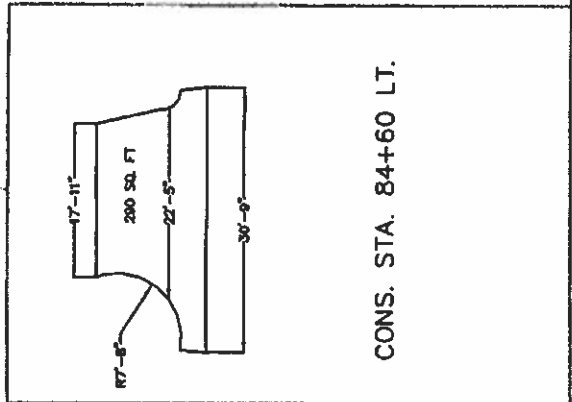

CONS. STA. 84+60 LT.

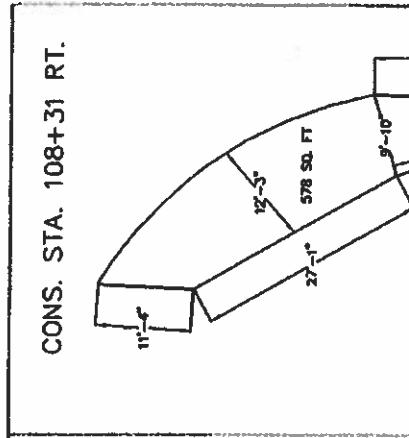

CONS. STA. 108+31 RT.

4 11	ASHTABULA COUNTY ENGINEERING DEPARTMENT TIMOTHY T. MARTIN - COUNTY ENGINEER	ASPHALT DRIVEWAY DETAILS FOOTMILLE RICHMOND ROAD C.H. SEC D-H	SCALE: DATE: 4/12/24	DRAWN: K.A.S REVISION:

TRANSITION AT MECHANICSVILLE--WINDSOR RD. (SOUTH)

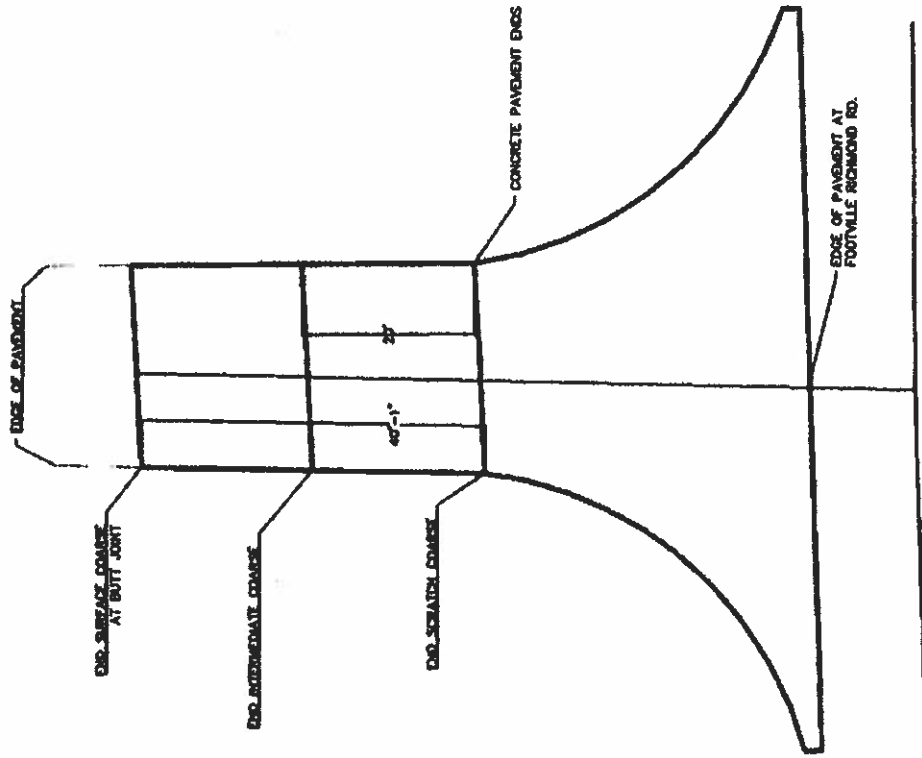
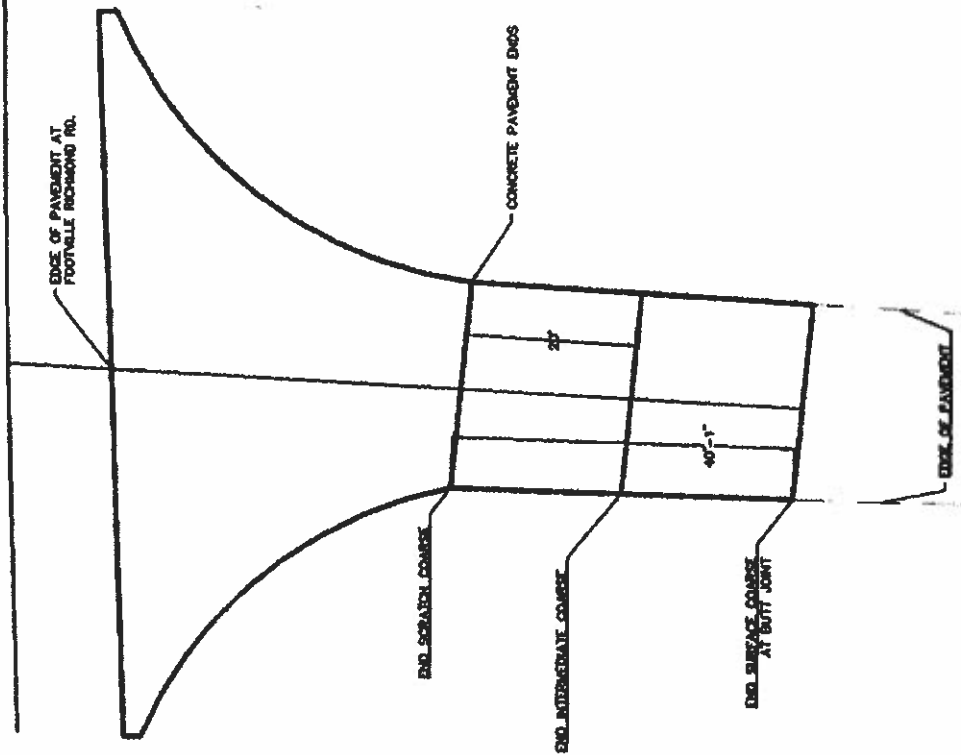

TRANSITION AT MECHANICSVILLE--WINDSOR RD. (NORTH)

5  
11

ASHTABULA COUNTY ENGINEERING  
DEPARTMENT  
TIMOTHY T. MARTIN--COUNTY ENGINEER

TRANSITION DETAIL  
FOOTVILLE RICHMOND ROAD C.H. SEC D-H

SCALE:  
DATE: 4/12/24

DRAWN: K.A.S  
REVISION:

TRANSITION AT HIGLEY RD.

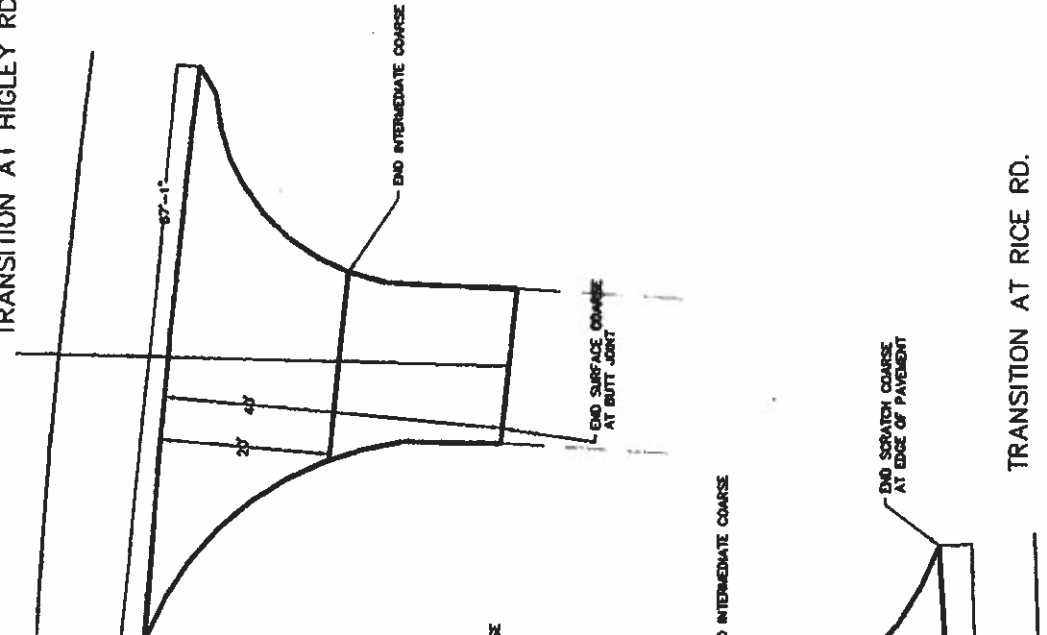

TRANSITION AT S.R. 534

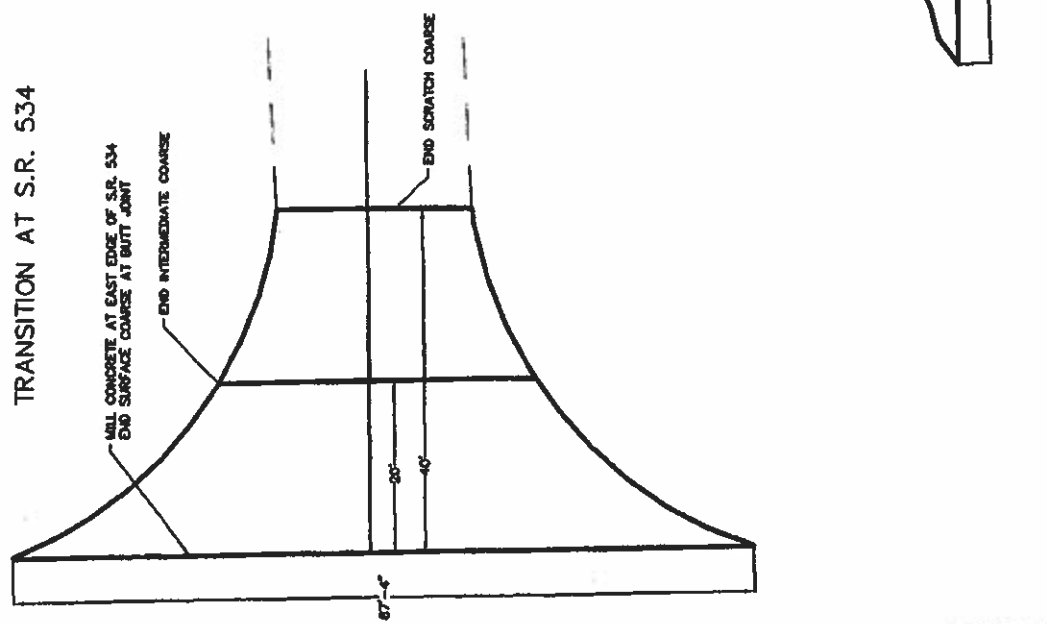

TRANSITION AT RICE RD.

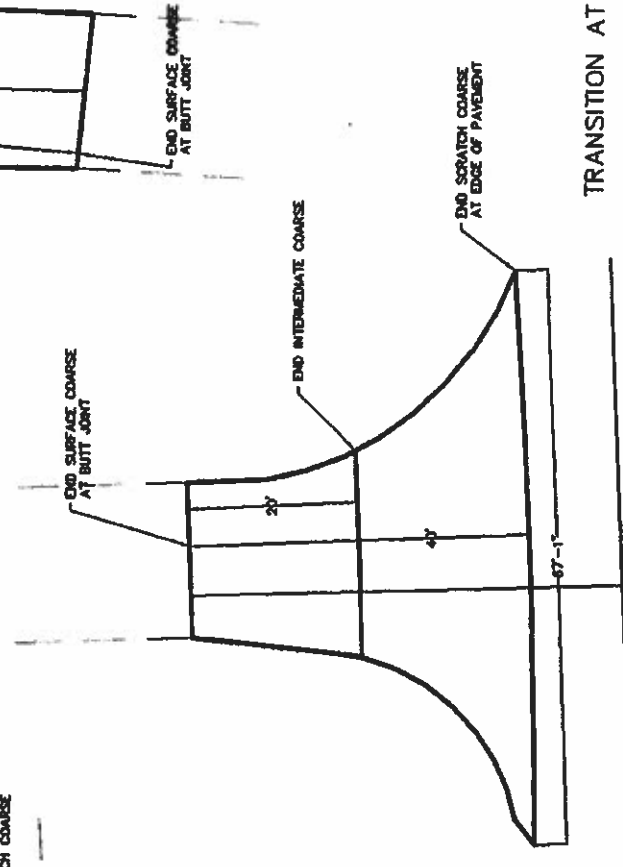

6 11	ASHTABULA COUNTY ENGINEERING DEPARTMENT	SCALE:	DRAWN: K.A.S
	TIMOTHY T. MARTIN—COUNTY ENGINEER	DATE: 4/12/24	REVISION:

TRANSITION DETAIL  
FOOTMILE RICHMOND ROAD C.H. SEC D-H

TRANSITION AT LAWTON RD.

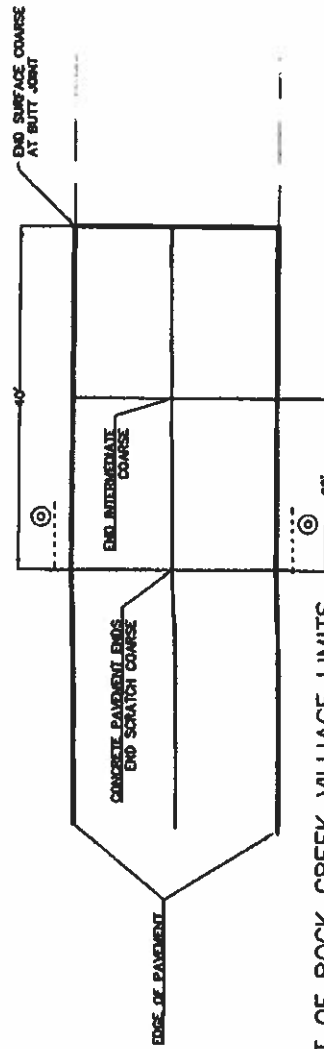
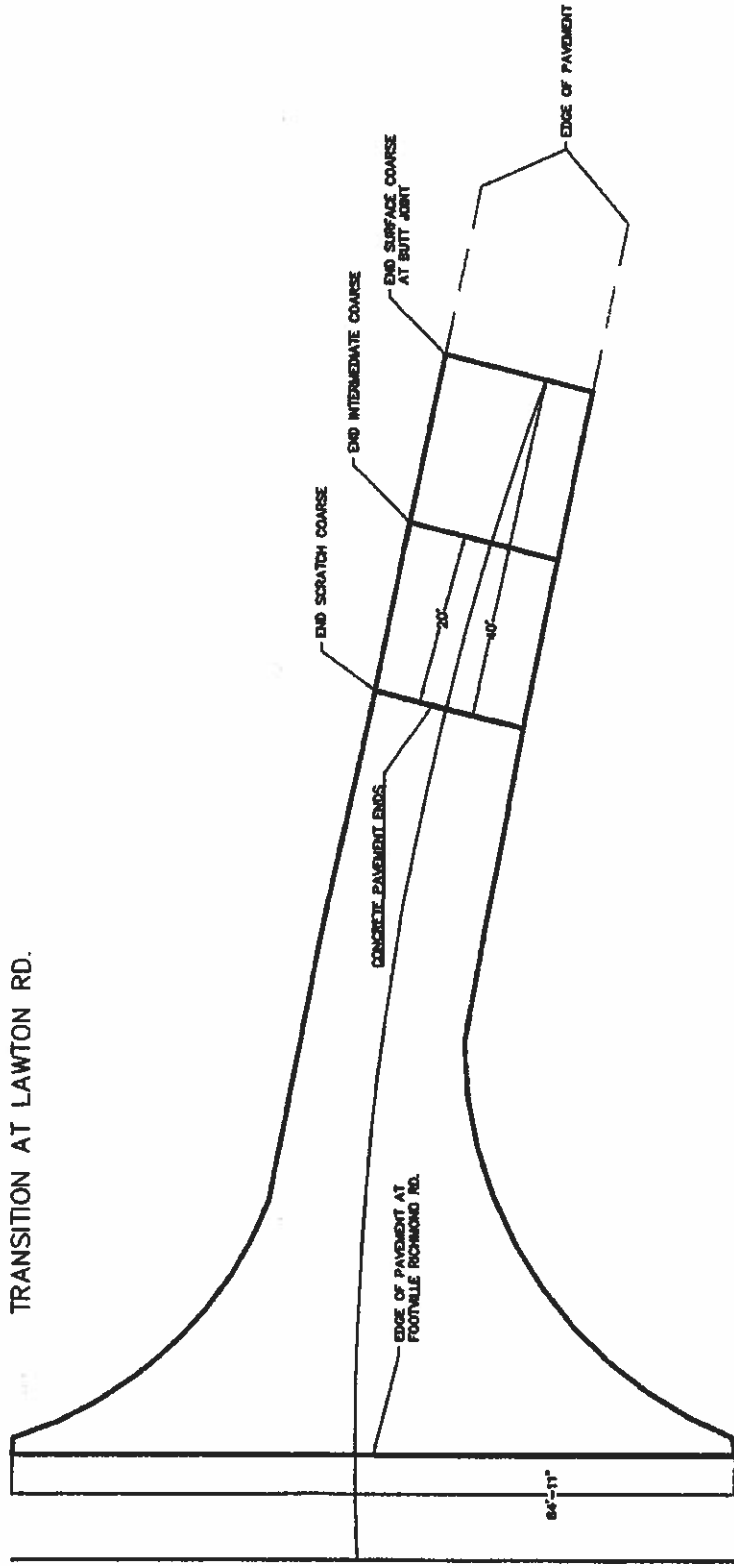

TRANSITION EAST OF ROCK CREEK VILLIAGE LIMITS

7 11	ASHTABULA COUNTY ENGINEERING DEPARTMENT TIMOTHY T. MARTIN-COUNTY ENGINEER	TRANSITION DETAIL FOOTVILLE RICHMOND ROAD C.H. SEC D-H	SCALE:	DRAWN: K.A.S
			DATE: 4/12/24	REVISION:

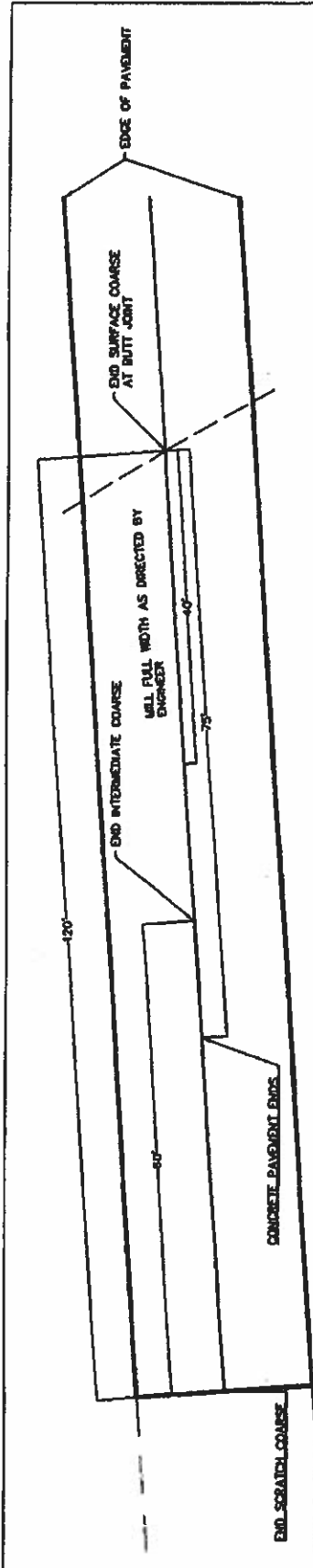

WEST APPROACH

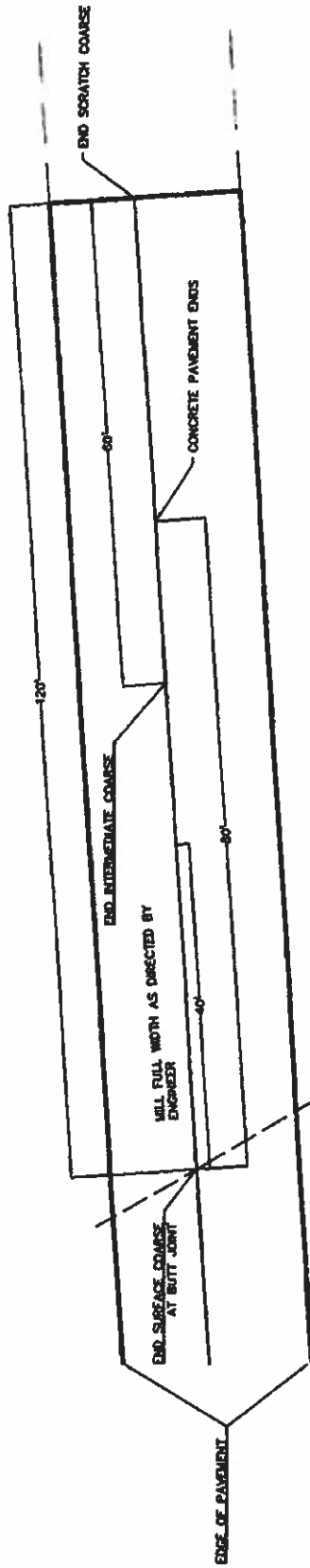

EAST APPROACH

8 11	ASHTABULA COUNTY ENGINEERING DEPARTMENT TIMOTHY T. MARTIN-COUNTY ENGINEER	BRIDGE OVER GRAND RIVER TRANSITIONS FOOTMILE RICHMOND ROAD C.H. SEC D-H	SCALE:	DRAWN: K.A.S
			DATE: 4/12/24	REVISION:

# FOOTVILLE RICHMOND ROAD

## WORK LIMITS

State Route 534 to ROCK CREEK VILLAGE LIMITS = 24,742'  
 (24,742' = 4.69 miles)

MAINLINE PAVING CALCULATIONS:  
 TANGENT AREA =  $22.5' \times 19,462' = 437,885$  Sq. Ft.  
 CURVE AREA =  $24' \times 5280' = 126,720$  Sq. Ft.  
 TOTAL AREA = 564,615 Sq. Ft.

COMPUTER ANALYSIS CALCULATIONS:  
 FOOTVILLE RICHMOND RD. TURNOUTS (ASPH) = 2,338 Sq. Ft.  
 FOOTVILLE RICHMOND RD. TURNOUTS (CON) = 7,020 Sq. Ft.  
 ASPHALT BRIDGE APPROACHES = 3,840 Sq. Ft.  
 S.R. 534 TURNOUT = 1,704 Sq. Ft.  
 13 ASPHALT DRIVES =  $13 \times (4' \times 18') = 936$  Sq. Ft.  
 4 NON-TYP. ASPHALT DRIVES = 3,110 Sq. Ft.  
 10 CONCRETE DRIVES = 2,042 Sq. Ft.

SURFACE COURSE = 564,615 + 2,338 + 7,020 + 936 = 574,909 Sq. Ft.  
 INTERMEDIATE COURSE =  $574,909 - 0.5(3,840) - 0.5(7,020 - 1,704) = 570,331$  Sq. Ft.  
 SCRATCH COURSE = 564,615 + 7,020 - 1,704 = 569,931 Sq. Ft.  
 CRACKING AND SEATING = 564,615 + 7,020 - 3,840 = 567,795 Sq. Ft.  
 CHIP SEAL = 564,615 + 7,020 - 3,840 = 567,795 Sq. Ft.

Item 321 Cracking and Seating  
 567,795 Sq. Ft.  
 567,795 / 9 = 63,089 Sq. Yds.

Item 407 Tack Coat  
 574,909 Sq. Ft.  
 574,909 / 9 = 63,878 Sq. Yds.  
 63,878 X 0.06 x 2 (lifts) = 7,666 Gal.

Item 422 Type A Chip Seal  
 567,795 Sq. Ft.  
 567,795 / 9 = 63,089 Sq. Yds.  
 63,089 / 22 Lbs. = 2,868 Tons  
 63,089 X 0.35 = 22,081 Gal.

Item 441 Scratch Type 1  
 569,931 Sq. Ft.  
 569,931 X (1" / 12") = 47,495 Cu. Ft.  
 47,495 / 27 = 1,760 Cu. Yds.

Item 441 Type 2 Intermediate Course  
 570,331 Sq. Ft.  
 570,331 X (2" / 12") = 95,056 Cu. Ft.  
 95,056 / 27 = 3,521 Cu. Yds.

Item 441 Type 1 Surface Course  
 574,909 Sq. Ft.  
 574,909 X (1.5" / 12") = 71,864 Cu. Ft.  
 71,864 / 27 = 2,662 Cu. Yds.

Item 441 Asphalt Driveways  
 3,110 Sq. Ft.  
 3,110 X (1.5" / 12") = 388.75 Cu. Ft.  
 388.75 / 27 = 15 Cu. Yds.

Item 452 Concrete Driveways  
 2,042 Sq. Ft.  
 2,042 / 9 = 227 Sq. Yds.

Item 202 Curb and Gutter Removed  
 Sta. 245+90 Lt. to Sta 249+67 Lt. = 377 Lin Ft.  
 Sta. 245+80 Rt. to Sta. 249+37 Rt. = 387 Lin Ft.  
 377+387 = 764 Lin Ft.

Item 609 Combination Curb and Gutter, Type 2  
 Sta. 248+82 Lt. to Sta 249+67 Lt. = 75 Lin Ft.  
 Sta. 248+27 Rt. to Sta. 249+37 Rt. = 140 Lin Ft.  
 377+387 = 215 Lin Ft.



ASHTABULA COUNTY ENGINEERING DEPARTMENT  
 TIMOTHY T. MARTIN-COUNTY ENGINEER

CALCULATIONS  
 FOOTVILLE RICHMOND ROAD C.H. SEC D-H

SCALE:

DRAWN: K.A.S

DATE: 4/12/24

REVISION:

# PAVING GENERAL NOTES AND PROCEDURES

- 1) THE CONSTRUCTION AND MATERIAL SPECIFICATIONS DATED 2023, PUBLISHED BY THE OHIO DEPARTMENT OF TRANSPORTATION (O.D.O.T.) SHALL GOVERN THIS PROJECT EXCEPT WHERE OTHERWISE NOTED IN THE CONTRACT DOCUMENTS. THE O.D.O.T. SPECIFICATIONS FOR ITEMS 441, IN ITS ENTIRETY SHALL APPLY.
  - 2) MINIMUM ASPHALT CONTENT SHALL BE 5.0% PLUS THE PERCENT ABSORPTION OF THE AGGREGATE AS DETERMINED IN ASTM C127-84, C128-84 TEST. THE CONTRACTOR SHALL PROVIDE A CERTIFIED ABSORPTION TEST RESULTS FOR FINE AND COARSE AGGREGATES. THIS SUPERCEDES ANY OTHER PUBLISHED SPECIFICATION.
  - 3) AT THE BID OPENING, THE CONTRACTOR SHALL SUBMIT A DATA SHEET SHOWING THE DESIGN OF ALL MIXES, SOURCE AND GRADATION OF AGGREGATE AND PROPOSED ASPHALT CONTENT FOR THE ASPHALT COURSES TO BE USED FOR THIS PROJECT. THE DATA SHEET WILL BE COMPARED TO O.D.O.T. STATISTICAL DATA FOR THE MATERIALS PROPOSED TO BE USED AND APPROVED OR DISAPPROVED.
  - 4) RECYCLED MATERIAL MAY BE USED WITH ENGINEER APPROVAL.
  - 5) ALL COARSE AGGREGATE SHALL BE LIMESTONE OR MATERIAL APPROVED BY THE ENGINEER.
  - 6) PLACE 441 TO DEPTH, WIDTH, AND LENGTH AS SHOWN ON THESE PLANS.
  - 7) ROLLING SHALL CONFORM TO O.D.O.T. SPEC. 401.13 AND 401.6.
  - 8) THE CONTRACTOR WILL GIVE THE COUNTY ENGINEER 2 DAYS NOTICE BEFORE COMMENCING WORK.
  - 9) ANY AND ALL EXTRA WORK SHALL BE DONE AT THE DIRECTION OF AND SUPERVISED BY THE ASHTABULA COUNTY ENGINEER.
  - 10) ALL BUTT JOINTS AND MAINTENANCE OF TRAFFIC AS PER STANDARD DRAWING MT-97.11 TO BE INCLUDED IN COST FOR 441 SURFACE COURSE.
  - 11) CONTRACTOR WILL TAPER ASPHALT AND CONCRETE DRIVEWAYS AND/OR INTERSECTIONS UP TO 6(SIX) FEET AS DIRECTED BY THE ENGINEER.
  - 12) PAVEMENT TO BE CLEANED AND SWEEPED PRIOR TO THE APPLICATION OF THE TACK COAT.
  - 13) O.D.O.T. SPECIFICATION 401.20 ASPHALT BINDER PRICE ADJUSTMENT, WILL NOT APPLY TO THIS CONTRACT.
  - 14) ALL MATERIAL, LABOR, AND EQUIPMENT USED TO FURNISH AND INSTALL MONUMENT BOXES AS SHOWN ON THE PLAN SHALL BE IN THE COST OF ITEM 623 MONUMENT ASSEMBLIES. MONUMENT ASSEMBLIES SHALL BE BACKFILLED WITH ASPHALT CONCRETE.
- THE ENGINEER WILL REFERENCE EACH MONUMENT BOX LOCATION FOR THE CONTRACTOR. THE CONTRACTOR SHALL ALSO PROVIDE TWO DAYS NOTICE TO THE ENGINEER TO SCHEDULE THE MARKING OF MONUMENT ASSEMBLIES LOCATIONS PRIOR TO INSTALLATION OF ITEM 448 SURFACE COURSE (2023).
- TO BE PLACED AT THE FOLLOWING CONSTRUCTION STATION LOCATIONS:
- |                |                |
|----------------|----------------|
| STA. 6+86.63   | STA. 200+09.86 |
| STA. 36+87.21  | STA. 205+78.83 |
| STA. 79+69.97  | STA. 209+75.81 |
| STB. 108+51.88 | STA. 220+91.58 |
| STA. 155+87.18 | STA. 235+18.83 |
| STA. 161+41.37 | STA. 237+29.75 |
| STA. 166+87.82 | STA. 248+81.05 |
| STA. 185+55.66 |                |
- WORK AS DESCRIBED ABOVE TO BE INCLUDED IN COST FOR 623 MONUMENT ASSEMBLIES REMOVED AND RESET.

10	ASHTABULA COUNTY ENGINEERING DEPARTMENT TIMOTHY T. MARTIN-COUNTY ENGINEER	SCALE:	
11	GENERAL NOTES FOOTVILLE RICHMOND ROAD C.H. SEC D-H	DATE:	4/12/24
		DRAWN:	K.A.S
		REVISION:	

# PAVING GENERAL NOTES AND PROCEDURES

- 15) WHERE DIRECTED, THE CONTRACTOR SHALL SET STRING LINES FOR HORIZONTAL GUIDANCE.
- 16) AFTER COMPLETION OF SURFACE COURSE, SEAL ALL BUTT JOINTS, MONUMENTS, AND DRIVEWAYS WITH ASPHALT BINDER AS DIRECTED BY ENGINEER. APPLY THE MATERIAL AT A UNIFORM WIDTH OF APPROXIMATELY 4 INCHES AND AT A RATE JUST SUFFICIENT TO FILL SURFACE VOIDS.

	ASHTABULA COUNTY ENGINEERING DEPARTMENT TIMOTHY T. MARTIN—COUNTY ENGINEER	GENERAL NOTES FOOTVILLE RICHMOND ROAD C.H. SEC D-H	SCALE: DATE: 4/12/24	DRAWN: K.A.S REVISION:
---	---	---	-------------------------	---------------------------

# Prevailing Wage Rate Skilled Crafts

Name of Union: Labor Hwy 2

Change # : LCN01-2023lbLaborHwy2

Craft : Laborer Group 1 Effective Date : 05/01/2023 Last Posted : 04/26/2023

	BHR		Fringe Benefit Payments					Irrevocable Fund		Total PWR	Overtime Rate	
			H&W	Pension	App Tr.	Vac.	Annuity	Other	LECET (*)			MISC (*)
Classification												
Laborer Group 1	\$35.05		\$8.20	\$4.05	\$0.45	\$0.00	\$1.00	\$0.00	\$0.10	\$0.00	\$48.85	\$66.37
Group 2	\$35.22		\$8.20	\$4.05	\$0.45	\$0.00	\$1.00	\$0.00	\$0.10	\$0.00	\$49.02	\$66.63
Group 3	\$35.55		\$8.20	\$4.05	\$0.45	\$0.00	\$1.00	\$0.00	\$0.10	\$0.00	\$49.35	\$67.12
Group 4	\$36.00		\$8.20	\$4.05	\$0.45	\$0.00	\$1.00	\$0.00	\$0.10	\$0.00	\$49.80	\$67.80
Watch Person	\$27.35		\$8.20	\$4.05	\$0.45	\$0.00	\$1.00	\$0.00	\$0.10	\$0.00	\$41.15	\$54.83
Apprentice	Percent											
0-1000 hrs	60.00	\$21.03	\$8.20	\$4.05	\$0.45	\$0.00	\$1.00	\$0.00	\$0.10	\$0.00	\$34.83	\$45.34
1001-2000 hrs	70.02	\$24.54	\$8.20	\$4.05	\$0.45	\$0.00	\$1.00	\$0.00	\$0.10	\$0.00	\$38.34	\$50.61
2001-3000 hrs	80.00	\$28.04	\$8.20	\$4.05	\$0.45	\$0.00	\$1.00	\$0.00	\$0.10	\$0.00	\$41.84	\$55.86
3001-4000 hrs	90.00	\$31.54	\$8.20	\$4.05	\$0.45	\$0.00	\$1.00	\$0.00	\$0.10	\$0.00	\$45.35	\$61.12
More Than 4000 hrs	100.00	\$35.05	\$8.20	\$4.05	\$0.45	\$0.00	\$1.00	\$0.00	\$0.10	\$0.00	\$48.85	\$66.37

**Special Calculation Note :** Watchman has no Apprentices. Tunnel Laborer rate with air-pressurized add \$1.00 to the above wage rate.

**Ratio :**  
 1 Journeymen to 1 Apprentice  
 3 Journeymen to 1 Apprentice thereafter

**Jurisdiction ( \* denotes special jurisdictional note ) :**  
 ASHTABULA, ERIE, HURON, LORAIN, LUCAS,  
 MAHONING, MEDINA, OTTAWA, PORTAGE,  
 SANDUSKY, STARK, SUMMIT, TRUMBULL, WOOD

**Special Jurisdictional Note :** Hod Carriers and Common Laborers - Heavy, Highway, Sewer, Waterworks, Utility, Airport, Railroad, Industrial and Building Site, Sewer Plant, Waste Water Treatment Facilities Construction

**Details :**  
 Group 1  
 Laborer (Construction); Plant Laborer or Yardman, Right-of-way Laborer, Landscape Laborer, Highway Lighting Worker, Signalization Worker, (Swimming) Pool Construction Laborer, Utility Man, \*Bridge Man, Handyman, Joint Setter, Flagperson, Carpenter Helper, Waterproofing Laborer, Slurry Seal, Seal Coating, Surface Treatment or Road Mix Laborer, Riprap Laborer & Grouter, Asphalt Laborer, Dump Man (batch trucks), Guardrail & Fence Installer, Mesh

Handler & Placer, Concrete Curing Applicator, Scaffold Erector, Sign Installer, Hazardous Waste (level D), Diver Helper, Zone Person and Traffic Control.

ridge Man will perform work as per the October 31, 1949, memorandum on concrete forms, by and between the United Brotherhood of Carpenters and Joiners of America and the Laborers' International Union of North America, which states in; "the moving, cleaning, oiling and carrying to the next point of erection, and the stripping of forms which are not to be re-used, and forms on all flat arch work shall be done by members of the Laborers' International Union of North America."

#### Group 2

Asphalt Raker, Screwman or Paver, Concrete Puddler, Kettle Man (pipeline), All Machine-Driven Tools (Gas, Electric, Air), Mason Tender, Brick Paver, Mortar Mixer, Skid Steer, Sheeting & Shoring Person, Surface Grinder Person, Screedperson, Water Blast, Hand Held Wand, Power Buggy or Power Wheelbarrow, Paint Striper, Plastic fusing Machine Operator, Rodding Machine Operator, Pug Mill Operator, Operator of All Vacuum Devices Wet or Dry, Handling of all Pumps 4 inches and under (gas, air or electric), Diver, Form Setter, Bottom Person, Welder Helper (pipeline), Concrete Saw Person, Cutting with Burning Torch, Pipe Layer, Hand Spiker (railroad), Underground Person (working in sewer and waterline, cleaning, repairing and reconditioning). Tunnel Laborer (without air), Caisson, Cofferdam (below 25 feet deep), Air Track and Wagon Drill, Sandblaster Nozzle Person, Hazardous Waste (level B), \*\*\*Lead Abatement, Hazardous Waste (level C)

\*\*\*Includes the erecting of structures for the removal, including the encapsulation and containment of Lead abatement process.

#### Group 3

Blast and Powder Person, Muckers will be defined as shovel men working directly with the miners, Wrencher (mechanical joints & utility pipeline), Yarnier, Top Lander, Hazardous Waste (level A), Concrete Specialist, Curb Setter, Cutter, Grade Checker, Concrete Crew in Tunnels. Utility pipeline Tappers, Waterline, Caulker, Signal Person will give the rate equal to the rate paid the Laborer classification for which the Laborer is signaling.

#### Group 4

Miner, Welder, Guniting Nozzle Person

A.) The Watchperson shall be responsible to patrol and maintain a safe traffic zone including but not limited to barrels, cones, signs, arrow boards, message boards etc.

The responsibility of a watchperson is to see that the equipment, job and office trailer etc. are secure.

# Prevailing Wage Rate Skilled Crafts

Name of Union: Operating Engineers - HevHwy Zone I

Change # : LCN01-2023IbLoc18hevhwyI

Craft : Operating Engineer Effective Date : 05/01/2023 Last Posted : 04/26/2023

	BHR		Fringe Benefit Payments					Irrevocable Fund		Total PWR	Overtime Rate	
			H&W	Pension	App Tr.	Vac.	Annuity	Other	LECET (*)			MISC (*)
Classification												
Operator Class A	\$42.98		\$9.01	\$6.25	\$0.85	\$0.00	\$0.00	\$0.09	\$0.00	\$0.05	\$59.23	\$80.72
Operator Class B	\$42.88		\$9.01	\$6.25	\$0.85	\$0.00	\$0.00	\$0.09	\$0.00	\$0.05	\$59.13	\$80.57
Operator Class C	\$41.84		\$9.01	\$6.25	\$0.85	\$0.00	\$0.00	\$0.09	\$0.00	\$0.05	\$58.09	\$79.01
Operator Class D	\$40.62		\$9.01	\$6.25	\$0.85	\$0.00	\$0.00	\$0.09	\$0.00	\$0.05	\$56.87	\$77.18
Operator Class E	\$35.33		\$9.01	\$6.25	\$0.85	\$0.00	\$0.00	\$0.09	\$0.00	\$0.05	\$51.58	\$69.24
Master Mechanic	\$43.23		\$9.01	\$6.25	\$0.85	\$0.00	\$0.00	\$0.09	\$0.00	\$0.05	\$59.48	\$81.09
<b>Apprentice</b>	<b>Percent</b>											
1st Year	50.00	\$21.49	\$9.01	\$6.25	\$0.85	\$0.00	\$0.00	\$0.09	\$0.00	\$0.05	\$37.74	\$48.49
2nd Year	60.00	\$25.79	\$9.01	\$6.25	\$0.85	\$0.00	\$0.00	\$0.09	\$0.00	\$0.05	\$42.04	\$54.93
3rd Year	70.00	\$30.09	\$9.01	\$6.25	\$0.85	\$0.00	\$0.00	\$0.09	\$0.00	\$0.05	\$46.34	\$61.38
4th Year	80.00	\$34.38	\$9.01	\$6.25	\$0.85	\$0.00	\$0.00	\$0.09	\$0.00	\$0.05	\$50.63	\$67.83
<b>Field Mech Trainee</b>												
1st year	50.00	\$21.49	\$9.01	\$6.25	\$0.85	\$0.00	\$0.00	\$0.09	\$0.00	\$0.05	\$37.74	\$48.49
2nd year	60.00	\$25.79	\$9.01	\$6.25	\$0.85	\$0.00	\$0.00	\$0.09	\$0.00	\$0.05	\$42.04	\$54.93
3rd year	70.00	\$30.09	\$9.01	\$6.25	\$0.85	\$0.00	\$0.00	\$0.09	\$0.00	\$0.05	\$46.34	\$61.38
4th year	80.00	\$34.38	\$9.01	\$6.25	\$0.85	\$0.00	\$0.00	\$0.09	\$0.00	\$0.05	\$50.63	\$67.83

**Special Calculation Note :** Other: Education & Safety Fund is \$0.09 per hour. \*Misc is National Training

**Ratio :** Jurisdiction ( \* denotes special jurisdictional note ):

For every (3) Operating Engineer Journeymen employed by ASHTABULA, CUYAHOGA, ERIE, GEAUGA, LAKE, the company, there may be employed (1) Registered

Apprentice or Trainee Engineer through the referral when they are available. An Apprentice, while employed as part of a crew per Article VIII, paragraph 69 will not be subject to the apprenticeship ratios in this collective bargaining agreement

LORAIN, MEDINA, PORTAGE, SUMMIT

**Special Jurisdictional Note :**

**Details :**

**\*\*Apprentices will receive a 10% increase on top of the percentages listed above provided they are operating bile equipment. Mechanic Trainees will receive 10% if required to have a CDL.**

**Class A - Air Compressors on Steel Erection; Asphalt Plant Engineers (Cleveland District Only); Barrier Moving Machine; Boiler Operators, Compressor Operators, or Generators, when mounted on a rig; Boom Trucks (all types); Cableways; Cherry Pickers; Combination- Concrete Mixers & Towers; Concrete Plants (over 4 yd capacity); Concrete Pumps; Cranes (all types); Compact Cranes track or rubber over 4,000 pounds capacity; Cranes self-erecting stationary, track or truck; Derricks (all types); Draglines; Dredges dipper, clam or suction; Elevating Graders or Euclid Loaders; Floating Equipment (all types); Gradalls; Helicopter Crew (Operator- hoist or winch); Hoes (all types); Hoisting Engines; Hoisting Engines, on shaft or tunnel work; Hydraulic Gantry (lifting system); Industrial-type Tractors; Jet Engine Dryer (D8 or D9) diesel Tractors; Locomotives (standard gauge); Maintenance Operators/Technicians (class A); Mixers, paving (single or double drum); Mucking Machines; Multiple Scrapers; Piledriving Machines (all types); Power Shovels, Prentice Loader; Quad 9 (double pusher); Rail Tamper (with automatic lifting and aligning device); Refrigerating Machines (freezer operation); Rotary Drills, on caisson work; Rough Terrain Fork Lift with winch/hoist; Side Booms; Slip Form Pavers; Survey Crew Party Chiefs; Tower Derricks; Tree Shredders; Trench Machines (over 24" wide); Truck Mounted Concrete Pumps; Tug Boats; Tunnel Machines and /or Mining Machines; Wheel Excavators.**

**Class B - Asphalt Pavers; Automatic Subgrade Machines, self-propelled (CMI-type); Bobcat-type and /or Skid Steer Loader with hoe attachment greater than 7000 lbs.; Boring Machine Operators (more than 48 inches); Bulldozers; Concrete Saws, Vermeer type; Endloaders; Horizontal Directional Drill (50,000 ft. lbs. thrust and over); Hydro Milling Machine; Kolman-type Loaders (production type-dirt); Lead Greasemen; Lighting and Traffic Signal Installation Equipment includes all groups or classifications; Maintenance Operators/Technicians, Class B; Material Transfer Equipment (shuttle buggy) Asphalt; Pettibone-Rail Equipment; Power Graders; Power Scrapers; Push Cats; Rotomills (all), Grinders and Planners of all types, Groovers (excluding walk-behinds); Trench Machines (24 inch wide and under).**

**Class C - A-Frames; Air Compressors, on tunnel work (low Pressure); Articulating/straight bed end dumps if assigned (minus \$4.00 per hour); Asphalt Plant Engineers (Portage and Summit Counties only); Bobcat-type and/or skid steer loader with or without attachments; Drones; Highway Drills (all types); HydroVac/Excavator (when a second person is needed, the rate of pay will be "Class E"); Locomotives (narrow gauge); Material Hoist/Elevators; Mixers, concrete (more than one bag capacity); Mixers, one bag capacity (side loader); Power Boilers (over 15 lbs. pressure); Pump Operators (installing or operating well Points); Pumps (4 inch and over discharge); Railroad Tie Inserter/Remover; Rollers, Asphalt; Rotovator (lime-soil Stabilizer); Switch & Tie Tampers (without lifting and aligning device); Utilities Operators, (small equipment); Welding Machines and Generators.**

**Class D - Backfillers and Tampers; Ballast Re-locator; Bar and Joint Installing Machines; Batch Plant Operators; Boring Machine Operators (48 inch or less); Bull Floats; Burlap and Curing Machines; Concrete Plants (capacity 4 yds. and under); Concrete Saws (multiple); Conveyors (highway); Crushers; Deckhands; Farm type tractors, with attachments (highway); Finishing Machines; Firemen, Floating Equipment (all types); Fork Lifts (highway), except masonry; Form Trenchers; Hydro Hammers; Hydro Seeders; Pavement Breakers (hydraulic or cable); Plant Mixers; Post Drivers; Post Hole Diggers; Power Brush Burners; Power Form Handling Equipment; Road Widening Trenchers; Rollers (brick, grade, macadam); Self-Propelled Power Spreaders; Self-Propelled Sub-Graders; Steam Firemen; Survey Instrument men; Tractors, pulling sheepsfoot rollers or graders; Vibratory Compactors, with integral power.**

**Class E - Compressors (portable, Sewer, Heavy and Highway); Cranes-Compact, track or rubber under 4,000 pound capacity; Drum Firemen (asphalt plant); Fueling and greasing (Primary Operator with Specialized CDL Endorsement Add \$3.00/hr); Generators; Inboard-Outboard Motor Boat Launches; Masonry Fork Lifts; Oil Heaters (asphalt plant); Oilers/Helpers; Power Driven Heaters (oil fired); Power Scrubbers; Power Sweepers; Pumps (under 4 inch discharge); Personal; Survey Rodmen or Chairmen; Tire Repairmen; VAC/ALLS.**

**Master Mechanic - Master Mechanic**

# Prevailing Wage Rate Skilled Crafts

Name of Union: Truck Driver Bldg & Hwy Class 1  
Locals 20,40,92,92b,100,175,284,438,377,637,908,957

Change # : LCN01-2023ibBldgHwy

Craft : Truck Driver Effective Date : 05/01/2023 Last Posted : 04/26/2023

	BHR		Fringe Benefit Payments					Irrevocable Fund		Total PWR	Overtime Rate	
			H&W	Pension	App Tr.	Vac.	Annuity	Other	LECET (*)			MISC (*)
Classification												
Truck Driver CLASS 1 4 wheel service, dump, and batch trucks; Drivers on dems; truck sweepers (not to include power sweepers & scrubbers)	\$31.24		\$7.75	\$9.20	\$0.20	\$0.00	\$0.00	\$0.00	\$0.00	\$0.00	\$48.39	\$64.01
Apprentice	Percent											
First 6 months	80.00	\$24.99	\$7.75	\$9.20	\$0.20	\$0.00	\$0.00	\$0.00	\$0.00	\$0.00	\$42.14	\$54.64
7-12 months	85.00	\$26.55	\$7.75	\$9.20	\$0.20	\$0.00	\$0.00	\$0.00	\$0.00	\$0.00	\$43.70	\$56.98
13-18 months	90.00	\$28.12	\$7.75	\$9.20	\$0.20	\$0.00	\$0.00	\$0.00	\$0.00	\$0.00	\$45.27	\$59.32
19-24 months	95.00	\$29.68	\$7.75	\$9.20	\$0.20	\$0.00	\$0.00	\$0.00	\$0.00	\$0.00	\$46.83	\$61.67
25-30 months	100.00	\$31.24	\$7.75	\$9.20	\$0.20	\$0.00	\$0.00	\$0.00	\$0.00	\$0.00	\$48.39	\$64.01

**Special Calculation Note :** No special calculations for this skilled craft wage rate are required at this time.

**Ratio :**

urneymen to 1 Apprentice

**Jurisdiction ( \* denotes special jurisdictional note ):**

ADAMS, ALLEN, ASHLAND, ASHTABULA, ATHENS, AUGLAIZE, BELMONT, BROWN, BUTLER, CARROLL, CHAMPAIGN, CLARK, CLERMONT, CLINTON, COLUMBIANA, COSHOCTON, CRAWFORD, DARKE, DEFIANCE, DELAWARE, ERIE, FAIRFIELD, FAYETTE, FRANKLIN, FULTON,

GALLIA, GREENE, GUERNSEY, HAMILTON,  
HANCOCK, HARDIN, HARRISON, HENRY,  
HIGHLAND, HOCKING, HOLMES, HURON,  
JACKSON, JEFFERSON, KNOX, LAWRENCE,  
LICKING, LOGAN, LORAIN, LUCAS, MADISON,  
MAHONING, MARION, MEDINA, MEIGS, MERCER,  
MIAMI, MONROE, MONTGOMERY, MORGAN,  
MORROW, MUSKINGUM, NOBLE, OTTAWA,  
PAULDING, PERRY, PICKAWAY, PIKE, PORTAGE,  
PREBLE, PUTNAM, RICHLAND, ROSS, SANDUSKY,  
SCIOTO, SENECA, SHELBY, STARK, SUMMIT,  
TRUMBULL, TUSCARAWAS, UNION, VAN WERT,  
VINTON, WARREN, WASHINGTON, WAYNE,  
WILLIAMS, WOOD, WYANDOT

**Special Jurisdictional Note :**

**Details :**

...SON,  
...CREEK  
...  
...

# Prevailing Wage Rate Skilled Crafts

Name of Union: Truck Driver Bldg & HevHwy Class 2  
Locals 20,40,92,92b,100,175,284,438,377,637,908,957

Change # : LCN01-2023ibBldgHevHwy

Craft : Truck Driver Effective Date : 05/01/2023 Last Posted : 04/26/2023

	BHR		Fringe Benefit Payments						Irrevocable Fund		Total PWR	Overtime Rate
			H&W	Pension	App Tr.	Vac.	Annuity	Other	LECET (*)	MISC (*)		
Classification												
Truck Driver CLASS 2 Tractor Trailer-Semi Tractor Trucks; Pole Trailers; Ready Mix Trucks; Fuel Trucks; 5 Axle & Over; Belly Dumps; Low boys - Heavy duty Equipment(irrespective load carried) when used exclusively for transportation; Truck Mechanics (when needed)	\$31.66		\$7.75	\$9.20	\$0.20	\$0.00	\$0.00	\$0.00	\$0.00	\$0.00	\$48.81	\$64.64
<b>Apprentice</b>	<b>Percent</b>											
First 6 months	80.00	\$25.33	\$7.75	\$9.20	\$0.20	\$0.00	\$0.00	\$0.00	\$0.00	\$0.00	\$42.48	\$55.14
7-12 months	85.00	\$26.91	\$7.75	\$9.20	\$0.20	\$0.00	\$0.00	\$0.00	\$0.00	\$0.00	\$44.06	\$57.52
13-18 months	90.00	\$28.49	\$7.75	\$9.20	\$0.20	\$0.00	\$0.00	\$0.00	\$0.00	\$0.00	\$45.64	\$59.89
19-24 months	95.00	\$30.08	\$7.75	\$9.20	\$0.20	\$0.00	\$0.00	\$0.00	\$0.00	\$0.00	\$47.23	\$62.27
25-30 months	100.00	\$31.66	\$7.75	\$9.20	\$0.20	\$0.00	\$0.00	\$0.00	\$0.00	\$0.00	\$48.81	\$64.64

**Special Calculation Note :** No special calculations for this skilled craft wage rate are required at this time.

**Ratio :**

3 Journeymen to 1 Apprentice

**Jurisdiction ( \* denotes special jurisdictional note ):**

ADAMS, ALLEN, ASHLAND, ASHTABULA, ATHENS, AUGLAIZE, BELMONT, BROWN, BUTLER, CARROLL, CHAMPAIGN, CLARK, CLERMONT, CLINTON, COLUMBIANA, COSHOCTON, CRAWFORD, DARKE, DEFIANCE, DELAWARE, ERIE, FAIRFIELD, FAYETTE, FRANKLIN, FULTON, GALLIA, GREENE, GUERNSEY, HAMILTON, HANCOCK, HARDIN, HARRISON, HENRY, HIGHLAND, HOCKING, HOLMES, HURON, JACKSON, JEFFERSON, KNOX, LAWRENCE, LICKING, LOGAN, LORAIN, LUCAS, MADISON, MAHONING, MARION, MEDINA, MEIGS, MERCER, MIAMI, MONROE, MONTGOMERY, MORGAN,

MORROW, MUSKINGUM, NOBLE, OTTAWA,  
PAULDING, PERRY, PICKAWAY, PIKE, PORTAGE,  
PREBLE, PUTNAM, RICHLAND, ROSS, SANDUSKY,  
SCIOTO, SENECA, SHELBY, STARK, SUMMIT,  
TRUMBULL, TUSCARAWAS, UNION, VAN WERT,  
VINTON, WARREN, WASHINGTON, WAYNE,  
WILLIAMS, WOOD, WYANDOT

**Special Jurisdictional Note :**

**Details :**

# Prevailing Wage Rate Skilled Crafts

Name of Union: Truck Driver Bldg & Hwy Class 3  
Locals 20,40,92,92b,100,175,284,438,377,637,908,957

Change # : LCN01-2023ibBldgHwy3

Craft : Truck Driver Effective Date : 05/01/2023 Last Posted : 04/26/2023

	BHR		Fringe Benefit Payments					Irrevocable Fund		Total PWR	Overtime Rate	
			H&W	Pension	App Tr.	Vac.	Annuity	Other	LECET (*)			MISC (*)
Classification												
Truck Driver CLASS 3 Articulated Dump Trucks; Ridge-Frame Trucks; Distributor Trucks)	\$32.66		\$7.75	\$9.20	\$0.20	\$0.00	\$0.00	\$0.00	\$0.00	\$0.00	\$49.81	\$66.14
Apprentice	Percent											
First 6 months	80.00	\$26.13	\$7.75	\$9.20	\$0.20	\$0.00	\$0.00	\$0.00	\$0.00	\$0.00	\$43.28	\$56.34
7-12 months	85.00	\$27.76	\$7.75	\$9.20	\$0.20	\$0.00	\$0.00	\$0.00	\$0.00	\$0.00	\$44.91	\$58.79
13-18 months	90.00	\$29.39	\$7.75	\$9.20	\$0.20	\$0.00	\$0.00	\$0.00	\$0.00	\$0.00	\$46.54	\$61.24
19-24 months	95.00	\$31.03	\$7.75	\$9.20	\$0.20	\$0.00	\$0.00	\$0.00	\$0.00	\$0.00	\$48.18	\$63.69
25-30 months	100.00	\$32.66	\$7.75	\$9.20	\$0.20	\$0.00	\$0.00	\$0.00	\$0.00	\$0.00	\$49.81	\$66.14

**Special Calculation Note :** No special calculations for this skilled craft wage rate are required at this time.

**Ratio :**

3 Journeymen to 1 Apprentice

**Jurisdiction ( \* denotes special jurisdictional note ):**

ADAMS, ALLEN, ASHLAND, ASHTABULA, ATHENS, AUGLAIZE, BELMONT, BROWN, BUTLER, CARROLL, CHAMPAIGN, CLARK, CLERMONT, CLINTON, COLUMBIANA, COSHOCTON, CRAWFORD, DARKE, DEFIANCE, DELAWARE, ERIE, FAIRFIELD, FAYETTE, FRANKLIN, FULTON, GALLIA, GREENE, GUERNSEY, HAMILTON, HANCOCK, HARDIN, HARRISON, HENRY, HIGHLAND, HOCKING, HOLMES, HURON, JACKSON, JEFFERSON, KNOX, LAWRENCE, LICKING, LOGAN, LORAIN, LUCAS, MADISON,

MAHONING, MARION, MEDINA, MEIGS, MERCER,  
MIAMI, MONROE, MONTGOMERY, MORGAN,  
MORROW, MUSKINGUM, NOBLE, OTTAWA,  
PAULDING, PERRY, PICKAWAY, PIKE, PORTAGE,  
PREBLE, PUTNAM, RICHLAND, ROSS, SANDUSKY,  
SCIOTO, SENECA, SHELBY, STARK, SUMMIT,  
TRUMBULL, TUSCARAWAS, UNION, VAN WERT,  
VINTON, WARREN, WASHINGTON, WAYNE,  
WILLIAMS, WOOD, WYANDOT

**Special Jurisdictional Note :**

**Details :**

1980  
11  
11

## **VII. PROPOSAL FORMS**

### **EQUAL EMPLOYMENT OPPORTUNITY REQUIREMENTS FOR SERVICE AND SUPPLY CONTRACTS**

#### **EQUAL EMPLOYMENT OPPORTUNITY COMPLIANCE CERTIFICATE**

As used in this Certificate, the terms "contract" and "subcontract" includes the term "Purchase Order" and all other agreements effectuating purchase of supplies or services.

This Certificate shall be renewed annually. Notwithstanding the foregoing, the certifications made herein shall remain applicable until completion of all non-exempt contracts/subcontracts awarded while this certificate is in effect. The undersigned Bidder certifies the following to the County:

- A. **REPORTS:** Within thirty (30) days after the County's award to the Bidder of any contract, and prior to each March 31 thereafter, during the performance of work under said contract, the Bidder shall file Standard Form 100, entitled "Equal Employment Opportunity Employer Information Report EEO-1" in accordance with instructions contained therein, unless the Bidder has either filed such report with the County within twelve (12) months preceding the date of the award or is not otherwise required by law or regulation to file such a report.
- B. **PRIOR REPORTS:** The Bidder, if it has participated in a previous contract or subcontract subject to the Equal Employment Opportunity Clause 41 C.F.R. Sec. 60-1.4 (a) (1) through (7), or the clause originally contained in Section 301 or Executive Order No. 10925, or the clause contained in Section 201 of the Executive Order No. 11114, has filed all required compliance reports. The Bidder shall obtain similar representations indicating submission of all required compliance reports, signed by proposed subcontractors, prior to awarding subcontracts not otherwise exempt from the Equal Employment Opportunity clause.
- C. **CERTIFICATION OF NON-SEGREGATED FACILITIES:** The Bidder certifies that it does not maintain or provide for its employees any segregated facilities at any of its establishments, and that it does not permit its employees to perform their services at any location, under its control, where segregated facilities are maintained. The Bidder certifies further that it will not maintain or provide for its employees any segregated facilities at any of its establishments and that it will not permit its employees to perform their services at any location, under its control, where segregated facilities are maintained. The Bidder agrees that a breach of this certification is a violation of the Equal Employment Opportunity Clause in this certificate. As used in this certification, the term "segregated facilities" means any waiting rooms, rest rooms, and wash rooms, restaurants and other eating areas, time clocks, locker rooms and other storage or dressing areas, parking lots, drinking fountains, recreation or entertainment areas, transportation, and

housing facilities provided for employees which are segregated by explicit directive or are in fact segregated on the basis of race, color, religion or natural origin, because of habit, local customs or otherwise. The Bidder further agrees that (except where it has obtained identical certifications from proposed subcontractors for specific time periods) it will obtain identical certifications from proposed subcontractors prior to the award of any subcontracts exceeding \$10,000.00 which are not exempt from the provisions of the Equal Employment Opportunity Clause; that it will retain such certifications in its files; and that it will forward the following notice to such proposed subcontractors (except where the proposed subcontractors have submitted identical certifications for specific time periods):

**Notice to Prospective Subcontractors of Requirement for Certification of Non-segregated Facilities:** A Certification of Non-segregated Facilities, as required by Section 60-1.8 of Title 41 of the Code of Federal Regulations, must be submitted prior to the award of a subcontract exceeding \$10,000.00 which is not otherwise exempt from the provisions of the Equal Employment Opportunity Clause.

NOTE: The penalty for making false statements in offers is prescribed in 18 U.S.C. 1001.

- D. **AFFIRMATIVE ACTION COMPLIANCE PROGRAM:** Prior to 120 days after receipt of any contract in the amount of \$50,000.00 or more from the County, Bidder, if it has fifty (50) or more employees and is not otherwise exempt under 41 C.F.R., Part 60-1, shall have developed for each of his establishments a written affirmative action compliance program as called for in 41 C.F.R., Sec. 60-1.40. Bidder will also require its lower-tier subcontractors who have fifty (50) or more employees and receive a subcontract of \$50,000.00 or more and who are not otherwise exempt under C.F.R., Part 60-1 to establish written affirmative action compliance programs in accordance with 41 C.F.R., Section 60-1.40.
- E. Bidders are responsible for EEO compliance as provided in Executive Order 11246 and implementing regulations Title 41, Chapter 60-4.2, 60-4.3 (Equal Employment Opportunity Clause & Notice of Standard Specifications), 60-250, and 60-741, when applicable.
- F. Bidder certifies that it is not currently in receipt of any outstanding letters of deficiencies, show cause, probable cause or other such notifications or noncompliance with EEO regulations.

Signed this 23 day of May, 2024

Bidder: Ponyak Paving Inc

(Signed) [Signature]

Printed Name & Title: Jay Stang Contract Administrator

DECLARATION OF PERSONAL PROPERTY TAX DELINQUENCY

OHIO REVISED CODE 5719.042

I, the undersigned, hereby certify that the bidder identified below  IS /  
 IS NOT charged at the time of submitting this Bid with any delinquent personal  
property taxes on the general tax list of personal property of the County.

COMPLETE THIS PARAGRAPH ONLY IF APPLICABLE:

The amount of any such due and unpaid delinquent tax and any due and unpaid  
penalties and interest is \$ 0.00.

Bidder: Ronyak Paving Inc

(Signed) [Signature]

Printed Name & Title: Joy Stang - Contract Administrator

STATE OF OHIO )

COUNTY OF ASHTABULA) ss:

Before me, a Notary Public, in and for said County, personally appeared the person identified  
above, who did sign this document after first affirming that the execution of this document was  
an authorized act on behalf of the above named Bidder.

IN TESTIMONY WHEREOF, I have affixed my hand and the seal of my office at this  
23 day of may, 2024.



MICHELLE JOSEPH  
Notary Public  
State of Ohio  
My Comm. Expires  
April 11, 2028

Michelle Joseph  
NOTARY PUBLIC

**CERTIFICATE OF BIDDER  
UNRESOLVED FINDINGS OF RECOVERY  
WITH AUDITOR OF STATE  
ORC 9.24 & 9.241**

I, the undersigned, hereby certify that the Bidder identified below:

**CHECK & COMPLETE ONLY ONE**

- has no unresolved findings of recovery with the State of Ohio Auditor, as defined by ORC 9.24 & 9.241;
- has the following unresolved findings of recovery with the State of Ohio Auditor, as defined by ORC 9.24 & 9.241:

---

---

---

---

Signed this 23 day of May, 2024

Bidder: Ponyak Paving Inc.

(Signed) 

Printed Name & Title: Joy Stang - Contract Administrator



Office of Auditor of State  
88 East Broad Street  
Post Office Box 1140  
Columbus, OH 43216-1140

Auditor of State - Unresolved Findings for Recovery Certified Search

(614) 466-4514  
(800) 282-0370

I have searched The Auditor of State's unresolved findings for recovery database using the following criteria:

Contractor's Information:

Name: **Ronyak, David**  
Organization: **ronyak paving inc**  
Date: **5/22/2024 4:17:37 PM**

This search produced the following list of 17 possible matches:

Name/Organization	Address
Bozanich, David	7842 Walnut Street
Clarich, David	1178 E. Aurora Road
Coffman, David	7770 Wrightstown Road
Donadeo, David	463 Vallie Lane
Frick, David	
Gleason, David	2700 Hemphill Dr.
Gray, David	1580 State Route 56
Hoffman, David	
Mohler, David	7922 Road U
Schneider, David	20088 Center Ridge Road
Schneider, David	20088 Center Ridge Road
Smalley, David	1292 Chester Way NW
Smith, David	3791 State Route 63
Electronic Classroom of Tomorrow	2275 Collingwood Boulevard
Industrial Hydraulics, Mr. Ron Baisden	108 S. 2nd St.
Next Frontier Academy	1127 Copley Road
Whitaker, Kwa David	2125 Superior Avenue

The above list represents possible matches for the search criteria you entered. Please note that pursuant to ORC 9.24, only the person (which includes an organization) actually named in the finding for recovery is prohibited from being awarded a contract.

If the person you are searching for appears on this list, it means that the person has one or more findings for recovery and is prohibited from being awarded a contract described in ORC 9.24, unless one of the exceptions in that section apply.

If the person you are searching for does not appear on this list, an initialed copy of this page can serve as documentation of your compliance with ORC 9.24(E).

Please note that pursuant to ORC 9.24, it is the responsibility of the public office to verify that a person to whom it plans to award a contract does not appear in the Auditor of State's database. The Auditor of State's office is not responsible for inaccurate search results caused by user error or other circumstances beyond the Auditor of State's control.

AFFIDAVIT IN COMPLIANCE WITH SECTION 3517.13 OF THE OHIO REVISED CODE

STATE OF OHIO )  
COUNTY OF ASHTABULA )SS:

Personally appeared before me the undersigned, as an individual or as a representative of

Ronyak Paving Inc. for a contract for Cracking + Sealing Concrete Pavement + Asphalt Paving  
(Name of Entity) (Type of Product or Service)

to be let by the Ashtabula County Engineer, who, being duly cautioned and sworn, makes the following statement with respect to prohibit activities constituting a conflict of interest or other violations under Ohio Revised Code Section 3517.13, and further states that the undersigned has the authority to make the following representation on behalf of himself or herself or of the business entity:

1. That none of the following has individually made since April 4, 2007 and that, if awarded a contract for the purchase of goods or services with a cost aggregating more than \$10,000 in a calendar year, none of the following individually will make, beginning on the date the contract is awarded and extending until one year following the conclusion of the contract, as an individual, one or more campaign contributions totaling in excess of \$1,000, to the Ashtabula County Engineer or his individual campaign committees:
  - a. myself;
  - b. any partner or owner or shareholder of the partnership (if applicable);
  - c. any owner of more than 20% of the corporation or business trust (if applicable);
  - d. each spouse of any person identified in (a) through (c) of this section;
  - e. each child seven years of age to seventeen years of age of any person identified in division (a) through (c) of this section (only applicable to contributions made on or after January 1, 2007).
  
2. That none of the following have collectively made since April 4, 2007 and that, if awarded a contract for the purchase of goods or services with a cost aggregating more than \$10,000 in a calendar year, none of the following collectively will make, beginning on the date the contract is awarded and extending until one year following the conclusion of the contract, one or more campaign contributions totaling in excess of \$2,000, to the Ashtabula County Engineer or his individual campaign committees:
  - a. myself;
  - b. any partner or owner or shareholder of the partnership (if applicable);
  - c. any owner of more than 20% of the corporation or business trust (if applicable);
  - d. each spouse of any person identified in (a) through (c) of this section;
  - e. each child seven years of age to seventeen years of age of any person identified in division (a) through (c) of this section.

Signature: [Handwritten Signature]  
Title: Joy Stang - Contract Administrator

SWORN TO BEFORE ME and subscribed in my presence this 23 day of May, 2024.

SEAL



MICHELLE JOSEPH  
Notary Public  
State of Ohio  
My Comm. Expires  
April 11, 2028

Michelle Joseph  
Notary Public

My commission expires: April 11, 2028

AFFIDAVIT IN COMPLIANCE WITH SECTION 3517.13 OF THE OHIO REVISED CODE

STATE OF OHIO )  
COUNTY OF ASHTABULA )SS:

Personally appeared before me the undersigned, as an individual or as a representative of

Ronyak Paving Inc for a contract for Cracking + Sealing Concrete Pavement + Asphalt Paving  
(Name of Entity) (Type of Product or Service)

to be let by the County of Ashtabula, who, being duly cautioned and sworn, makes the following statement with respect to prohibit activities constituting a conflict of interest or other violations under Ohio Revised Code Section 3517.13, and further states that the undersigned has the authority to make the following representation on behalf of himself or herself or of the business entity:

1. That none of the following has **individually** made since April 4, 2007 and that, if awarded a contract for the purchase of goods or services with a cost aggregating more than \$10,000 in a calendar year, none of the following **individually** will make, beginning on the date the contract is awarded and extending until one year following the conclusion of the contract, as an individual, one or more campaign contributions totaling in excess of \$1,000, to any member of the Ashtabula County Board of Commissioners or their individual campaign committees:
  - a. myself;
  - b. any partner or owner or shareholder of the partnership (if applicable);
  - c. any owner of more than 20% of the corporation or business trust (if applicable);
  - d. each spouse of any person identified in (a) through (c) of this section;
  - e. each child seven years of age to seventeen years of age of any person identified in division (a) through (c) of this section (only applicable to contributions made on or after January 1, 2007).
  
2. That none of the following have **collectively** made since April 4, 2007 and that, if awarded a contract for the purchase of goods or services with a cost aggregating more than \$10,000 in a calendar year, none of the following **collectively** will make, beginning on the date the contract is awarded and extending until one year following the conclusion of the contract, one or more campaign contributions totaling in excess of \$2,000, to any member of the Ashtabula County Board of Commissioners or their individual campaign committees:
  - a. myself;
  - b. any partner or owner or shareholder of the partnership (if applicable);
  - c. any owner of more than 20% of the corporation or business trust (if applicable);
  - d. each spouse of any person identified in (a) through (c) of this section;
  - e. each child seven years of age to seventeen years of age of any person identified in division (a) through (c) of this section.

Signature: [Handwritten Signature]  
Title: Joy Shang - Contract Administrator

SWORN TO BEFORE ME and subscribed in my presence this 23 day of May, 2024.

SEAL



MICHELLE JOSEPH  
Notary Public  
State of Ohio  
My Comm. Expires  
April 11, 2028

[Handwritten Signature]  
Notary Public

My commission expires: April 11, 2028

**PROPOSAL**

Ashtabula County, Ohio

April 24, 2024

**To the Board of County Commissioners:**

The undersigned Bidder certifies the pre-bid examination, in its entirety, of all Bid Documents contained in or referenced by this Proposal, including the Notice to Bidders, Instructions to Bidders, General & Supplemental Provisions, Standard Specifications, Scope of Work, Plans & Specifications, and Planned Bid Items & Quantities, which shall govern this improvement and are made a part of this Proposal and the ensuing contract.

**DESCRIPTION OF THE IMPROVEMENT**

Footville Richmond Road Cracking & Seating Concrete Pavement & Asphalt Paving

---

---

---

The undersigned Bidder proposes to furnish any and all material, tools, labor, transportation, machinery, appliances, and appurtenances necessary, and to prosecute to full completion, the Work called for hereunder, and in consideration thereof, to accept from the County, as full payment for the completion of each item as specified, the respective unit or lump sum price hereafter set forth.

The undersigned Bidder agrees that, if this Proposal is accepted, said Bidder will, within ten (10) days after notification of such acceptance, enter into the contract for the performance of the Work proposed and, as a guarantee of the faithful performance thereof, to furnish at the time of executing the contract, a bond in the amount equal to 100% of the total Bid price, with a Surety subject to the approval of the County.

The Bidder hereby agrees that the County has the right to reject any and all bids, and the Bidder will not dispute the correctness of the quantities used to determine the lowest and best bid.

Accompanying this Bid is a bid guarantee or bond payable to the County. Upon any failure to execute the Contract or provide an adequate performance bond as aforesaid, it is agreed that the undersigned Bidder shall forfeit the bid guarantee or bond accompanying the proposal to the County, to the extent allowed by law.



## PROPOSAL

COUNTY ENGINEERS DEPT.  
ASHTABULA COUNTY

REPORT NO \_\_\_\_\_

For Improving Road: Footville-Richmond Road D to H  
In The Township Of: Trumbull & Morgan  
Improving By: Cracking and Seating Concrete Pavement and Asphalt Paving

Pavement Width: 22-24 feet existing  
Roadway Width:  
Length In Feet, Miles: 24,742 feet; 4.69 miles  
(From SR 534 east to Rock Creek Village)  
Bridge Type:  
Bridge Span:

Items	Quantities	DESCRIPTION	\$ Unit	\$ Total
202	764	Curb and Gutter Removed (Lin Ft.)	8.00	6,112.00
321	63089	Cracking and Seating Non-Reinforced Concrete Pavement (Sq. Yd.)	1.00	63,089.00
407	7666	Tack Coat (Gal.)	2.00	15,332.00
422	63089	Aggregate, Single Chip Seal, Type A (Sq. Yds.)	1.00	63,089.00
422	22081	Emulsion, Single Chip Seal, Type A (Sq. Yds.)	2.25	49,682.25
441	1760	1" Asphalt Concrete Intermediate Course Type 1, (448) PG 64-22 (Scratch) (Cu. Yds.)	180.00	316,800.00
441	3521	2" Asphalt Concrete Intermediate Course Type 2, (448) PG 64-22 (Cu. Yds.)	150.00	528,150.00
441	2662	1.5" Asphalt Concrete Surface Course Type 1, (448) PG 64-22 (Cu. Yds.)	175.00	465,580.00
441	15	2" Asphalt Concrete Surface Course Type 1, (449) PG 64-22 (Driveways) (Cu. Yds.)	375.00	5,625.00
452	227	Non-Reinforced Concrete Pavement (Driveways) (Sq. Yds.)	135.00	30,645.00
609	215	Combination Curb and Gutter, Type 2 (Lin. Ft.)	60.00	12,900.00
614	Lump	Maintaining Traffic	94,499.75	94,499.75
623	15	Monument Assemblies Removed and Reset (Each)	980.00	14,700.00

TOTAL COST AND EXPENSE:

\$1,666,474.00

  
 Authorized Signature \_\_\_\_\_ Joy Stang \_\_\_\_\_  
 Print name

Contractor: Pomusk Paving Inc  
 Address: 14376 N. Chesire St  
Burton, OH 44021  
 Phone: 440-834-1988

Joy Stang - contractadmin@jwdservices.com  
 Name and email address for contract signee

**BID GUARANTY AND  
CONTRACT BOND**

(SECTION 153.571 Ohio Revised Code)

**KNOW ALL PERSONS BY THESE PRESENTS**, That we, the undersigned \_\_\_\_\_  
Ronyak Paving, Inc. 11938 Mayfield Road, Bld. A, Chardon, OH 44024

(Name and Address)

as Principal and Atlantic Specialty Insurance Company as Surety, are hereby held and firmly bound

unto Ashtabula County Commissioners

\_\_\_\_\_ as Obligee in the penal sum of the dollar amount of

the bid submitted by the Principal to the Obligee on May 23, 2024  
to undertake the Project known as:

Footville-Richmond Rd. Improvements Phases 1 & 2

The penal sum referred to herein shall be the dollar amount of the Principal's bid to the Obligee, incorporating any additive or deductive alternate proposals made by the principal on the date referred to above to the Obligee, which are accepted by the Obligee. In no case shall the penal sum exceed the amount of

\_\_\_\_\_ dollars (\$ \_\_\_\_\_)

(If the above line is left blank, the penal sum will be the full amount of the Principal's bid, including alternates. Alternatively, if completed, the amount stated must not be less than the full amount of the bid, including alternates, in dollars and cents. A percentage is not acceptable.) For the payment of the penal sum well and truly to be made, we hereby jointly and severally bind ourselves, our heirs, executors, administrators, successors, and assigns.

THE CONDITION OF THE ABOVE OBLIGATION IS SUCH, that whereas the above named Principal has submitted a bid on the above referred project;

NOW, THEREFORE, if the Obligee accepts the bid of the Principal and the Principal fails to enter into a proper contract in accordance with the bid, plans, details, specifications and bills of material; and in the event the Principal pays to the Obligee the difference not to exceed ten percent of the penalty hereof between the amount specified in the bid and such larger amount for which the Obligee may in good faith contract with the next lowest bidder to perform the work covered by the bid; or in the event the Obligee does not award the contract to the next lowest bidder and resubmits the project for bidding, the Principal will pay the Obligee the difference not to exceed ten percent of the penalty hereof between the amount specified in the bid, or the costs, in connection with the resubmission, of printing new contract documents, required advertising and printing and mailing notices to prospective bidders, whichever is less, then this obligation shall be void, otherwise to remain in full force and effect. If the Obligee accepts the bid of the Principal and the Principal within ten days after the awarding of the contract, enters into a proper contract in accordance with the bid, plans, details, specifications and bills of material, which said contract is made a part of this bond the same as though set forth herein; and

IF THE SAID Principal shall well and faithfully perform each and every condition of such contract; and indemnify the Oblige against all damage suffered by failure to perform such contract according to the provisions thereof and in accordance with the plans, details, specifications and bills of material therefore; and shall pay all lawful claims of subcontractors, material suppliers, and laborers, for labor performed and material furnished in the carrying forward, performing, or completing of said contract; we agreeing and assenting that this undertaking shall be for the benefit of any material supplier or laborer having a just claim, as well as for the Oblige herein; then this obligation shall be void; otherwise the same shall remain in full force and effect; it being expressly understood and agreed that the liability of the Surety for any and all claims hereunder shall in no event exceed the penal amount of this obligation as herein stated.

THE SAID Surety hereby stipulates and agrees that no modifications, omissions, or additions, in or to the terms of said contract or in or to the plans and specifications therefore shall in any wise affect the obligations of said Surety on this bond, and it does hereby waive notice of any such modifications, omissions or additions to the terms of the contract or to the work or to the specifications.

SIGNED AND SEALED This 23rd day of May, 2024

PRINCIPAL:

SURETY:

Ronyak Paving, Inc.

Atlantic Specialty Insurance Company

BY:



BY:

  
Attorney-In-Fact Logan Liptak

TITLE: Joy Stancy - Contract Administrator

Surety Company Address:  
605 Highway, 169 North, Ste. 800  
Plymouth, MN 55441  
P. 800-662-0156  
Breiff@intactinsurance.com

Surety Agent's Address:  
The Fedeli Group  
5005 Rockside Road, Ste. 500  
Independence, OH 44131  
P. 216-328-8080  
F. 216-328-8081  
lliptak@thefedeligroup.com



# Power of Attorney

KNOW ALL MEN BY THESE PRESENTS, that ATLANTIC SPECIALTY INSURANCE COMPANY, a New York corporation with its principal office in Plymouth, Minnesota, does hereby constitute and appoint: Daniel Fedell, Jill LaBondano, Kevin S. Keller, Logan Liptak, Melanie Blankenburg, Scott Liptak, Sharon Brickman, each individually if there be more than one named, its true and lawful Attorney-in-Fact, to make, execute, seal and deliver, for and on its behalf as surety, any and all bonds, recognizances, contracts of indemnity, and all other writings obligatory in the nature thereof; provided that no bond or undertaking executed under this authority shall exceed in amount the sum of: unlimited and the execution of such bonds, recognizances, contracts of indemnity, and all other writings obligatory in the nature thereof in pursuance of these presents, shall be as binding upon said Company as if they had been fully signed by an authorized officer of the Company and sealed with the Company seal. This Power of Attorney is made and executed by authority of the following resolutions adopted by the Board of Directors of ATLANTIC SPECIALTY INSURANCE COMPANY on the twenty-fifth day of September, 2012:

Resolved: That the President, any Senior Vice President or Vice-President (each an "Authorized Officer") may execute for and in behalf of the Company any and all bonds, recognizances, contracts of indemnity, and all other writings obligatory in the nature thereof, and affix the seal of the Company thereto; and that the Authorized Officer may appoint and authorize an Attorney-in-Fact to execute on behalf of the Company any and all such instruments and to affix the Company seal thereto; and that the Authorized Officer may at any time remove any such Attorney-in-Fact and revoke all power and authority given to any such Attorney-in-Fact.

Resolved: That the Attorney-in-Fact may be given full power and authority to execute for and in the name and on behalf of the Company any and all bonds, recognizances, contracts of indemnity, and all other writings obligatory in the nature thereof, and any such instrument executed by any such Attorney-in-Fact shall be as binding upon the Company as if signed and sealed by an Authorized Officer and, further, the Attorney-in-Fact is hereby authorized to verify any affidavit required to be attached to bonds, recognizances, contracts of indemnity, and all other writings obligatory in the nature thereof.

This power of attorney is signed and sealed by facsimile under the authority of the following Resolution adopted by the Board of Directors of ATLANTIC SPECIALTY INSURANCE COMPANY on the twenty-fifth day of September, 2012:

Resolved: That the signature of an Authorized Officer, the signature of the Secretary or the Assistant Secretary, and the Company seal may be affixed by facsimile to any power of attorney or to any certificate relating thereto appointing an Attorney-in-Fact for purposes only of executing and sealing any bond, undertaking, recognizance or other written obligation in the nature thereof, and any such signature and seal where so used, being hereby adopted by the Company as the original signature of such officer and the original seal of the Company, to be valid and binding upon the Company with the same force and effect as though manually affixed.

IN WITNESS WHEREOF, ATLANTIC SPECIALTY INSURANCE COMPANY has caused these presents to be signed by an Authorized Officer and the seal of the Company to be affixed this first day of January, 2023.

STATE OF MINNESOTA  
HENNEPIN COUNTY



By

Sarah A. Kolar, Vice President and General Counsel

On this first day of January, 2023, before me personally came Sarah A. Kolar, Vice President and General Counsel of ATLANTIC SPECIALTY INSURANCE COMPANY, to me personally known to be the individual and officer described in and who executed the preceding instrument, and she acknowledged the execution of the same, and being by me duly sworn, that she is the said officer of the Company aforesaid, and that the seal affixed to the preceding instrument is the seal of said Company and that the said seal and the signature as such officer was duly affixed and subscribed to the said instrument by the authority and at the direction of the Company.

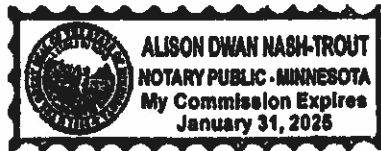

Notary Public

I, the undersigned, Secretary of ATLANTIC SPECIALTY INSURANCE COMPANY, a New York Corporation, do hereby certify that the foregoing power of attorney is in full force and has not been revoked, and the resolutions set forth above are now in force.

Signed and sealed. Dated 23 day of May, 2024



Kara L.B. Barrow, Secretary

This Power of Attorney expires  
January 31, 2025



Atlantic Specialty Insurance Company
Period Ended 12/31/2022

Dollars displayed in thousands

Table with 2 columns: Admitted Assets and Liabilities and Surplus. Rows include Investments (Bonds, Preferred Stocks, etc.), Total Admitted Assets (3,780,047), Liabilities (Loss Reserves, etc.), Total Liabilities (2,921,725), and Capital and Surplus (Common Capital Stock, etc.), Total Liabilities and CSB (3,780,047).

State of Minnesota
County of Hennepin

I, Kara L.B. Barrow, Secretary of Atlantic Specialty Insurance Company do hereby certify that the foregoing statement is a correct exhibit of the assets and liabilities of the said Company, on the 31st day of December, 2022, according to the best of my information, knowledge and belief.

[Signature of Kara L.B. Barrow]
Secretary

Subscribed and sworn to, before me, a Notary Public of the State of Minnesota on this 16th day of March, 2023.

[Signature of Kerri Riechers]
Notary Public



Office of Risk Assessment  
50 West Town Street  
Third Floor - Suite 300  
Columbus, Ohio 43215  
(614)644-2858  
Fax(614)644-3256  
www.insurance.ohio.gov

**Ohio Department of Insurance**

Mike DeWine - Governor

Judith French - Director



**Certificate of Compliance**

Issued 03/14/2024

Effective 04/02/2024

Expires 04/01/2025

I, Judith French, hereby certify that I am the Director of Insurance in the State of Ohio and have supervision of insurance business in said State and as such I hereby certify that

**ATLANTIC SPECIALTY INSURANCE COMPANY**

of New York is duly organized under the laws of this State and is authorized to transact the business of insurance under the following section(s) of the Ohio Revised Code:

**Section 3929.01 (A)**

Aircraft	Multiple Peril - Commercial
Allied Lines	Multiple Peril - Farmowners
Boiler & Machinery	Multiple Peril - Homeowners
Burglary & Theft	Noncancellable A & H
Collectively Renewable A & H	Nonrenew- Stated Reasons (A&H)
Commercial Auto - Liability	Ocean Marine
Commercial Auto - No Fault	Other
Commercial Auto - Physical Damage	Other Accident only
Credit	Other Liability
Credit Accident & Health	Private Passenger Auto - Liability
Fidelity	Private Passenger Auto - No Fault
Fire	Private Passenger Auto - Physical Damage
Glass	Surety
Group Accident & Health	Workers Compensation
Guaranteed Renewable A & H	
Inland Marine	
Medical Malpractice	

**ATLANTIC SPECIALTY INSURANCE COMPANY** certified in its annual statement to this Department as of December 31, 2022 that it has admitted assets in the amount of \$3,750,047,271, liabilities in the amount of \$2,921,725,080, and surplus of at least \$828,322,191.

IN WITNESS WHEREOF, I have hereunto subscribed my name and caused my seal to be affixed at Columbus, Ohio, this day and date.

*Judith L. French*

Judith French, Director



**VII. ARTICLES OF AGREEMENT**

For use in award of contract.

The Bidder is not to fill in the following blanks.

This Agreement is made and entered into by the **County of Ashtabula**, acting herein by its Board of County Commissioners, and the Contractor identified below, hereinafter called the Contractor.

**WITNESSETH:**

The Contractor, for and in consideration of certain payments to be made as specified herein, hereby covenants and agrees to perform and execute all provisions of its Proposal for construction of the subject public improvement, including fulfillment of the requirements of the Notice to Bidders, Instructions to Bidders, General & Supplemental Provisions, Standard Specifications, Scope of Work, Plans & Specifications, and Planned Bid Items & Quantities, and to be governed by the provisions contained therein, setting forth duties, relations and obligations of the County, Contractor and the Surety, which are hereto attached and made a part hereof, and agrees to fully and completely perform the Work described hereby in a manner to achieve completion thereof by or before a completion date of November 8, 2024.

In consideration of the performance by the Contractor of the covenants and agreements as herein set forth, the County hereby covenants and agrees to pay the Contractor according to the schedule of rates and prices set forth in the attached Proposal of said Contractor, and at the time and in the manner hereinafter set forth herein.

IN WITNESS WHEREOF, the parties to this Agreement have hereunto set their hands

effective this \_\_\_\_\_ day of \_\_\_\_\_, 20\_\_\_\_\_.

**CONTRACTOR:** Ronyak Paving, Inc.  
(full name)

(signed) Jay Steing Contract Administrator  
Contractor's mailing address.

Ronyak Paving, Inc.

PO Box 567

Burton, OH

(440) 334-1988 ( ) \_\_\_\_\_  
Phone Fax

**County Engineer:**

\_\_\_\_\_  
Timothy T. Martin, P.E., P.S.

**Affirmation of Contractor**

I, the undersigned, certify that I am the Secretary or equivalent of the Contractor identified above. I hereby affirm that the person who signed hereinabove on behalf of said Contractor was duly authorized to do so, and that said contract was signed for and on behalf of said Contractor by authority of its governing body.

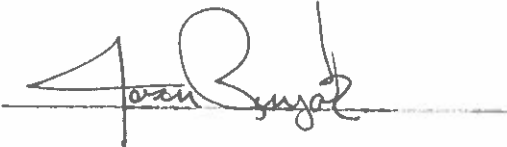
(Signed)  \_\_\_\_\_

Printed Name & Title: Jason Pongak - Vice President

Signature Page

Agreement Title: Footville Richmond Road Cracking & Seating Concrete Pavement &  
Asphalt Paving #318

Approved as to Legal Form Only:

By:   
Colleen M. O'Toole,  
Ashtabula County Prosecutor

Dated: 4/11/2024, 2024  
M# 01024  
Matrix# 2024-CN-0096

Signature Page

Agreement Title: Footville Richmond Road Cracking & Seating Concrete Pavement &  
Asphalt Paving #318

Contract expected:

By: Ashtabula County Board of Commissioners

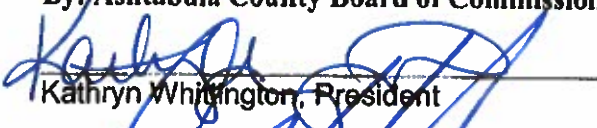
  
Kathryn Whittington, President

  
Casey Kozlowski, Commissioner

  
J.P. Ducro IV, Commissioner

Dated: June 20, 2024





**Bureau of Workers' Compensation**

30 W. Spring St.  
Columbus, OH 43215

### Certificate of Ohio Workers' Compensation

This certifies that the employer listed below participates in the Ohio State Insurance Fund as required by law. Therefore, the employer is entitled to the rights and benefits of the fund for the period specified. This certificate is only valid if premiums and assessments, including installments, are paid by the applicable due date. To verify coverage, visit [www.bwc.ohio.gov](http://www.bwc.ohio.gov), or call 1-800-644-6292.

RECEIVED

This certificate must be conspicuously posted.

MAY 2 2023

Policy number and employer  
00955256

Period Specified Below  
07/01/2023 to 07/01/2024

RONYAK PAVING INC  
PO BOX 567  
BURTON OH 44021-0567



[www.bwc.ohio.gov](http://www.bwc.ohio.gov)  
Issued by: BWC

Administrator/CEO

You can reproduce this certificate as needed.

### Ohio Bureau of Workers' Compensation

#### Required Posting

Section 4123.54 of the Ohio Revised Code requires notice of rebuttable presumption. Rebuttable presumption means an employee may dispute or prove untrue the presumption (or belief) that alcohol, marihuana or a controlled substance not prescribed by the employee's physician is the proximate cause (main reason) of the work-related injury.

The burden of proof is on the employee to prove the presence of alcohol, marihuana or a controlled substance was not the proximate cause of the work-related injury. An employee who tests positive or refuses to submit to chemical testing may be disqualified for compensation and benefits under the Workers' Compensation Act.



**Bureau of Workers' Compensation**

You must post this language with the Certificate of Ohio Workers' Compensation.

**FISCAL OFFICER'S CERTIFICATE**  
5705.41 O.R.C.

The undersigned, County Auditor of Ashtabula County, hereby certifies that the amount required to meet the obligations of the County during the year 2024 under the Agreement has been lawfully appropriated for that purpose, and is in the Treasury of the County or in the process of collection and free from any previous encumbrances to the credit of:

2222.007.301-603; not to exceed \$1,666,474.00.

**Agreement Title: RESOLUTION APPROVING A CONTRACT WITH RONYAK PAVING INC. FOR FOOTVILLE RICHMOND ROAD CH 12 PHASE I SECTION F-H AND PHASE II SECTION D-F ROAD FOR CRACK AND SEAR AND PAVING PROJECT FOR THE COUNTY HIGHWAY/ENGINEER DEPARTMENT, QUOTATION # 318.**



\_\_\_\_\_  
**David Thomas, Ashtabula County  
Auditor**

Date: June 10, 2024