

RESOLUTION APPROVING THIRD PARTY AGREEMENT BY AND BETWEEN THE ASHTABULA COUNTY BOARD OF COMMISSIONERS, GENEVA CITY, AND GEAUGA HIGHWAY CO. FOR PY25 CDBG – GENEVA CITY DEPOT STREET STORM SEWER PROJECT IN GENEVA CITY - CDBG ALLOCATION THROUGH THE DEPARTMENT OF PLANNING AND DEVELOPMENT

WHEREAS, Jake Brand, Director of the Department of Planning and Development, has presented an agreement for the approval of the Board, to-wit:

Scope: Third party agreement for Depot Street Storm Sewer Project in Geneva City

Parties: Ashtabula County Commissioners, 25 W. Jefferson St. Jefferson OH 44047
Geneva City, 44 North Forest Street, Geneva, Ohio 44041
Geauga Highway Co., 15651 W. High St., Unit 2, Middlefield, OH 44062

Cost: Total project cost of \$1,075,165.35.
Not to exceed, \$153,000.00 from PY25 CDBG Allocation Grant

Term: begins upon board approval and completed no later than August 28, 2026; now

THEREFORE, BE IT RESOLVED, By the Board of Commissioners of Ashtabula County, Ohio, that the agreement, as noted above, is approved in accordance with the copy now on file in this office.

BE IT FURTHER RESOLVED that the President of the Board, on behalf of the Board of Commissioners of Ashtabula County, is authorized to execute any and all necessary documents.

**ASHTABULA COUNTY COMMISSIONERS
CERTIFICATION PAGE**

Resolution No. 2026-229

May 12, 2026

RESOLUTION APPROVING THIRD PARTY AGREEMENT BY AND BETWEEN THE ASHTABULA COUNTY BOARD OF COMMISSIONERS, GENEVA CITY, AND GEAUGA HIGHWAY CO. FOR PY25 CDBG – GENEVA CITY DEPOT STREET STORM SEWER PROJECT IN GENEVA CITY - CDBG ALLOCATION THROUGH THE DEPARTMENT OF PLANNING AND DEVELOPMENT

Upon the motion of Kathryn L. Whittington, seconded by J.P. Ducro IV.

VOTE:

**Casey R. Kozlowski
Kathryn L. Whittington
J.P. Ducro IV**

**Aye
Aye
Aye**

CERTIFICATE OF CLERK

IT IS HEREBY CERTIFIED that the foregoing is a true and correct transcript of a resolution acted upon and duly passed by the Board of County Commissioners of Ashtabula County, Ohio, on the date noted above.



Lisa Hawkins, Clerk of the Board
Board of County Commissioners
Ashtabula County, Ohio

NOTICE OF AWARD

TO: Geauga Highway Co.
15651 W High St., Unit 2
Middlefield, Ohio 44062

DATE: April 16, 2026

PROJECT: GENEVA STREETScape IMPROVEMENTS
Phase 2 Streetscape – Appalachian Trail Community Grant Funded
Depot Street Storm Sewer – CDBG Funded

You are notified that your Bid which was opened on April 9, 2026 has been accepted for items in the amount of \$1,075,161.35 at the unit bid prices as reflected in the bid tabulation contained herein for Phase 2 – Streetscape Base Bid and Alternates A & B and Depot Street Storm Sewer.

You are required by the Instructions to Bidders to execute the Agreement and furnish the required Bonds, Certificates of Insurance, and other documents within 10 calendar days from the date of receipt of this Notice.

Failure to comply with these conditions within the time specified will entitle Owner to consider your Bid in default, to annul this Notice and to declare your Bid Security forfeited.

The Owner will return to you one (1) fully signed set of the contract documents.

CITY OF GENEVA

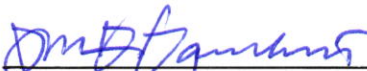

Joseph Varckette, City Manager

ACKNOWLEDGMENT

GEAUGA HIGHWAY CO.



John Bojce, President

RESOLUTION NO. 3665

A RESOLUTION AUTHORIZING THE ACCEPTANCE OF THE BID OF GEUGA HIGHWAY CO. OF MIDDLEFIELD FOR THE PHASE 2 STREETScape AND DEPOT STREET STORM SEWER, AND DECLARING AN EMERGENCY.

NOW BE IT RESOLVED by the Council of the City of Geneva, State of Ohio, that:

SECTION I. The bid of Geauga Highway Co. of Middlefield, Ohio for the Phase 2 Streetscape, Depot Street Storm Sewer project, and both alternatives (clock and decorative sign) in the amount of \$1,075,161.35 be accepted, being the lowest and best bid for said improvements as set forth in the specifications of the city.

SECTION II. The City Manager is hereby authorized to enter into a contract with the above-named company for the Phase 2 Streetscape, Depot Street Storm Sewer and both alternates (clock and decorative sign) as stated above.

SECTION III. That it is found and determined that all formal actions of this Council concerning and relating to the passage of this Resolution were adopted in an open meeting of this Council, and that all deliberations of this Council and any of its committees that resulted in such formal action, were in meetings open to the public, in compliance with the law.

SECTION IV. That this resolution is hereby declared to be an emergency measure for the immediate preservation of the public peace, health, and safety of the City of Geneva and therefore, this resolution shall take effect and be in full force immediately upon its passage.

Passed this 13th day of April, 2026.

John V. Barbo
President of Council

Attest: Phyllis A. Dunlap
Clerk of Council

CERTIFICATE
I hereby certify that the foregoing
is a true copy of Resolution No.

3665
adopted by the Council of
the City of Geneva, Ohio on

4/13/2026 4/13/2026
Date Phyllis A. Dunlap
Clerk of Council

CONTRACT

FOR GENEVA STREETSCAPE IMPROVEMENTS
Phase 2 Streetscape – Appalachian Trail Community Grant Funded
Depot Street Storm Sewer – CDBG Funded

THIS AGREEMENT, made and entered into at Geneva, Ohio, this _____ day of _____, 2026, by and between the City of Geneva (“OWNER”), Ohio, Ashtabula County Board of Commissioners (CDBG Recipient) and Geauga Highway Co. (“CONTRACTOR”).

WITNESSETH: That the said CONTRACTOR has agreed and by this presents does agree with the OWNER for the consideration hereinafter mentioned and contained, and under penalty expressed in a bond given with these presents, and herein contained or hereunto annexed, to furnish at its own cost and expense, all the necessary tools, equipment, materials, labor, and tests in an expeditious, substantial and workmanlike manner, the equipment and appurtenances herein contemplated, commencing work within 20 days from the date of the Notice to Proceed and executing the work within the time and in the manner specified and in conformity with the requirements set forth in this Contract.

The following form essential parts of the Contract (may vary with project).

1. Advertisement for Bids/Public Notice to Bidders
2. Instruction to Bidders
3. Bid Forms and Proposal
4. Contract Forms and Exhibits
5. Contract Bond – ORC 153.571 or ORC 153.57
6. Contract Provisions
7. General Conditions
8. Supplementary Conditions
9. Specifications
10. Specific Project Requirements
11. Prevailing Wage Rate Schedule
12. Contract Drawings

The CONTRACTOR agrees and understands that the work on this contract shall be subject to the acceptance of the OWNER based upon and in accordance with the contract specifications and contract plans and drawings on file in the office of the OWNER.

The Contractor agrees that each individual employed by the Contractor or any Subcontractor and engaged in work on the project under this contract shall be paid by prevailing wage established by the Department of Industrial Relations of the State of Ohio or the U.S. Department of Labor (Davis-Bacon Act) as detailed in the section titled "Wage Rates." This shall occur regardless of any contractual relationship which may be said to exist between the Contractor or any Subcontractor and such individual.

The CONTRACTOR shall proceed with the said work in a prompt and diligent manner and shall do the several parts thereof, at such times and in such order as the OWNER may direct. Further he shall complete the whole of said work in accordance with the specifications and contract drawings to the satisfaction of the OWNER on or before the time stated, and in default of completion within the time as fixed, the CONTRACTOR shall pay to the OWNER as liquidated damages, an amount equal to \$1,000.00, for each and every day (Sundays and legal holidays excepted) the completion of the work may be delayed beyond the date fixed in the manner and as stipulated.

It is hereby mutually agreed that the OWNER is to pay and the CONTRACTOR is to receive, as full compensation for furnishing all materials and labor in building, constructing and testing and in all respect completing the herein described work and appurtenances in the manner and under the conditions herein specified, the prices stipulated in the proposal herein contained or hereto annexed and the total contract sum is \$1,075,161.35.

This Contract shall be in full force and effect from the date of execution by the parties.

IN WITNESS WHEREOF: The parties hereunto affixed their signature the day and year first mentioned above.

GEAUGA HIGHWAY CO.

John Bojcek, President

CITY OF GENEVA

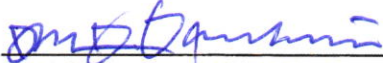

Joseph Varckette, City Manager

I hereby certify that funds in the amount of One Million Seventy-Five Thousand One Hundred Sixty-One 35/100 Dollars (\$1,075,161.35) necessary for the foregoing Contract have been appropriated and are in the Treasury, or are in the process of collection, or are available through grants and/or loans from other funding sources.



Traci Welch, Finance Director

APPROVED AS TO FORM:

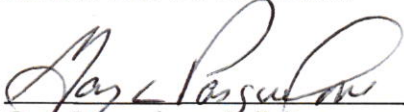

Gary Pasqualone, Solicitor

CDBG RECIPIENT: ASHTABULA COUNTY BOARD OF COMMISSIONERS (Depot Street)

Casey R. Kozlowski, President

CDBG RECIPIENT: ASHTABULA COUNTY COMMISSIONERS HOLD HARMLESS

The Owner and Contractor agree to hold the Ashtabula County Board of Commissioners (CDBG Recipient) harmless from and against claims, damages, losses, and expense, including but not limited to attorney's fees, arising out of or resulting from negligence or misconduct in relation to the work defined in the contract.

LEGAL REVIEW

Agreement Title: GENEVA STREETSCAPE IMPROVEMENTS
 Depot Street Storm Sewer – CDBG Funded (City of Geneva)

An Agreement between Geauga Highway Co., the City of Geneva,
and CDBG Recipient: Ashtabula County Board of Commissioners, for the **GENEVA
STREETSCAPE IMPROVEMENTS - DEPOT STREET STORM SEWER.**
(CDBG _____).

The above titled agreement is approved as to legal form:

April R. Grabman, County Prosecutor

Date

FISCAL OFFICER'S CERTIFICATE

Conforming with O.R.C. § 5705.41

The undersigned Auditor of Ashtabula County, hereby certifies that the amount required to meet the obligations of Ashtabula County during the year 2026 under the Agreement has been lawfully appropriated for that purpose, and is in the Treasury of the County or in the process of collection to the credit of:

One Hundred Forty-Seven Thousand Six hundred Twenty-Two & 00/100 dollars (\$147,622.00) **in the amount not to exceed \$147,622.00** and free from any previous encumbrances.

Agreement Title: **Construction Contract**

By and Between the Ashtabula County Board of Commissioners, by and through the Department of Environmental Services, and Geauga Highway Co. for the purposes of providing construction services pertinent to the **GENEVA STREETScape IMPROVEMENTS - DEPOT STREET STORM SEWER (CDBG Funded)** project in the Ashtabula County General Sewer District.

SIGNED

Scott Yamamoto
Ashtabula County Auditor

Date

**THE CONTRACTOR SHALL FURNISH THE FOLLOWING ITEMS
WITHIN 10 DAYS OF NOTIFICATION OF AWARD:**

- A) **CERTIFICATE OF INSURANCE FOR
CONTRACTOR'S PUBLIC LIABILITY INSURANCE POLICY**
*Owner, Ashtabula County Board of Commissioners, Verdantas LLC, and CT Consultants, Inc.
Named as Additional Insured*
- B) **CERTIFICATE OF INSURANCE FOR
OWNER'S AND CONTRACTOR'S PROTECTIVE POLICY**
Owner Named as Insured (No Additional Insured)
- C) **CERTIFICATE OF WORKER'S COMPENSATION**
- D) **CONTRACT BOND THAT COMPLIES WITH ORC 153.54 AND 153.57**

* D above is not required if a bond complying with ORC 153.54 and 153.571 (rollover bond) was submitted at time of bid.



INSURANCE BINDER

DATE (MM/DD/YYYY)

04/24/26

THIS BINDER IS A TEMPORARY INSURANCE CONTRACT, SUBJECT TO THE CONDITIONS SHOWN ON PAGE 2 OF THIS FORM.

AGENCY ARNOLD INSURANCE AGENCY, INC. 1400 HAFT DRIVE REYNOLDSBURG, OH 43068		COMPANY EMPLOYERS MUTUAL CASUALTY CO		BINDER # BBD6835																			
PHONE (A/C, No, Ext): 614-863-0455		FAX (A/C, No): 614-863-2474		<input type="checkbox"/> THIS BINDER IS ISSUED TO EXTEND COVERAGE IN THE ABOVE NAMED COMPANY PER EXPIRING POLICY #:																			
CODE:		SUB CODE:		DESCRIPTION OF OPERATIONS / VEHICLES / PROPERTY (Including Location) GENEVA STREETScape IMPROVEMENTS, PHASE 2 STREETScape, DEPOT STREET STORM SEWER																			
AGENCY CUSTOMER ID:		INSURED AND MAILING ADDRESS CITY OF GENEVA C/O GEAUGA HIGHWAY CO. 44 NORTH FOREST STREET GENEVA, OH 44041		<table border="1"> <tr> <th colspan="2">EFFECTIVE</th> <th colspan="2">TIME</th> <th colspan="2">EXPIRATION</th> </tr> <tr> <th>DATE</th> <th></th> <th></th> <th></th> <th>DATE</th> <th>TIME</th> </tr> <tr> <td>04/24/26</td> <td></td> <td>12:01</td> <td><input checked="" type="checkbox"/> AM <input type="checkbox"/> PM</td> <td>04/24/27</td> <td><input checked="" type="checkbox"/> 12:01 AM <input type="checkbox"/> NOON</td> </tr> </table>		EFFECTIVE		TIME		EXPIRATION		DATE				DATE	TIME	04/24/26		12:01	<input checked="" type="checkbox"/> AM <input type="checkbox"/> PM	04/24/27	<input checked="" type="checkbox"/> 12:01 AM <input type="checkbox"/> NOON
EFFECTIVE		TIME		EXPIRATION																			
DATE				DATE	TIME																		
04/24/26		12:01	<input checked="" type="checkbox"/> AM <input type="checkbox"/> PM	04/24/27	<input checked="" type="checkbox"/> 12:01 AM <input type="checkbox"/> NOON																		

COVERAGES**LIMITS**

TYPE OF INSURANCE	COVERAGE / FORMS	DEDUCTIBLE	COINS %	AMOUNT
PROPERTY CAUSES OF LOSS <input type="checkbox"/> BASIC <input type="checkbox"/> BROAD <input type="checkbox"/> SPEC				
GENERAL LIABILITY <input type="checkbox"/> COMMERCIAL GENERAL LIABILITY <input type="checkbox"/> CLAIMS MADE <input type="checkbox"/> OCCUR <input checked="" type="checkbox"/> OWNERS & CONTRACTORS <input type="checkbox"/> PROTECTIVE POLICY	RETRO DATE FOR CLAIMS MADE:			EACH OCCURRENCE \$ 1,000,000 DAMAGE TO RENTED PREMISES \$ MED EXP (Any one person) \$ PERSONAL & ADV INJURY \$ GENERAL AGGREGATE \$ 2,000,000 PRODUCTS - COMP/OP AGG \$
VEHICLE LIABILITY <input type="checkbox"/> ANY AUTO <input type="checkbox"/> OWNED AUTOS ONLY <input type="checkbox"/> SCHEDULED AUTOS <input type="checkbox"/> HIRED AUTOS ONLY <input type="checkbox"/> NON-OWNED AUTOS ONLY				COMBINED SINGLE LIMIT \$ BODILY INJURY (Per person) \$ BODILY INJURY (Per accident) \$ PROPERTY DAMAGE \$ MEDICAL PAYMENTS \$ PERSONAL INJURY PROT \$ UNINSURED MOTORIST \$
VEHICLE PHYSICAL DAMAGE DED <input type="checkbox"/> COLLISION: _____ <input type="checkbox"/> OTHER THAN COL: _____	<input type="checkbox"/> ALL VEHICLES <input type="checkbox"/> SCHEDULED VEHICLES			ACTUAL CASH VALUE STATED AMOUNT \$
GARAGE LIABILITY <input type="checkbox"/> ANY AUTO				AUTO ONLY - EA ACCIDENT \$ OTHER THAN AUTO ONLY: EACH ACCIDENT \$ AGGREGATE \$
EXCESS LIABILITY <input type="checkbox"/> UMBRELLA FORM <input type="checkbox"/> OTHER THAN UMBRELLA FORM	RETRO DATE FOR CLAIMS MADE:			EACH OCCURRENCE \$ AGGREGATE \$ SELF-INSURED RETENTION \$
WORKER'S COMPENSATION AND EMPLOYER'S LIABILITY				PER STATUTE E.I. EACH ACCIDENT \$ E.I. DISEASE - EA EMPLOYEE \$ E.I. DISEASE - POLICY LIMIT \$
SPECIAL CONDITIONS / OTHER COVERAGES				FEES \$ TAXES \$ ESTIMATED TOTAL PREMIUM \$

NAME & ADDRESS

CITY OF GENEVA 44 NORTH FOREST STREET GENEVA, OH 44041	<input checked="" type="checkbox"/> ADDITIONAL INSURED	<input type="checkbox"/> LOSS PAYEE	<input type="checkbox"/> MORTGAGEE
	<input type="checkbox"/> LENDER'S LOSS PAYABLE		
	LOAN #:		
AUTHORIZED REPRESENTATIVE 			

CONDITIONS

This Company binds the kind(s) of insurance stipulated on page 1 of this form. The Insurance is subject to the terms, conditions and limitations of the policy(ies) in current use by the Company.

This binder may be cancelled by the Insured by surrender of this binder or by written notice to the Company stating when cancellation will be effective. This binder may be cancelled by the Company by notice to the Insured in accordance with the policy conditions. This binder is cancelled when replaced by a policy. If this binder is not replaced by a policy, the Company is entitled to charge a premium for the binder according to the Rules and Rates in use by the Company.

Applicable in Arizona

Binders are effective for no more than ninety (90) days.

Applicable in California

When this form is used to provide insurance in the amount of one million dollars (\$1,000,000) or more, the title of the form is changed from "Insurance Binder" to "Cover Note".

Applicable in Colorado

With respect to binders issued to renters of residential premises, home owners, condo unit owners and mobile home owners, the insurer has thirty (30) business days, commencing from the effective date of coverage, to evaluate the issuance of the insurance policy.

Applicable in Delaware

The mortgagee or Obligee of any mortgage or other instrument given for the purpose of creating a lien on real property shall accept as evidence of insurance a written binder issued by an authorized insurer or its agent if the binder includes or is accompanied by: the name and address of the borrower; the name and address of the lender as loss payee; a description of the insured real property; a provision that the binder may not be canceled within the term of the binder unless the lender and the insured borrower receive written notice of the cancellation at least ten (10) days prior to the cancellation; except in the case of a renewal of a policy subsequent to the closing of the loan, a paid receipt of the full amount of the applicable premium, and the amount of insurance coverage.

Chapter 21 Title 25 Paragraph 2119

Applicable in Florida

Except for Auto Insurance coverage, no notice of cancellation or nonrenewal of a binder is required unless the duration of the binder exceeds 60 days. For auto insurance, the insurer must give 5 days prior notice, unless the binder is replaced by a policy or another binder in the same company.

Applicable in Maryland

The insurer has 45 business days, commencing from the effective date of coverage to confirm eligibility for coverage under the insurance policy.

Applicable in Michigan

The policy may be cancelled at any time at the request of the insured.

Applicable in Montana

No binder shall be valid beyond the issuance of the policy with respect to which it was given or beyond 90 days from its effective date, whichever period is the shorter. If the policy has not been issued, a binder may be extended or renewed beyond such 90 days with the written approval of the insurer.

Applicable in Nevada

Any person who refuses to accept a binder which provides coverage of less than \$1,000,000.00 when proof is required: (A) Shall be fined not more than \$500.00, and (B) is liable to the party presenting the binder as proof of insurance for actual damages sustained therefrom.

Applicable in Oklahoma

All policies shall expire at 12:01 a.m. standard time on the expiration date stated in the policy.

Applicable in Oregon

Binders are effective for no more than ninety (90) days. A binder extension or renewal beyond such 90 days would require the written approval by the Director of the Department of Consumer and Business Services.

Applicable in the Virgin Islands

This binder is effective for only ninety (90) days. Within thirty (30) days of receipt of this binder, you should request an insurance policy or certificate (if applicable) from your agent and/or insurance company.



**Bureau of Workers'
Compensation**

30 W. Spring St.
Columbus, OH 43215

Certificate of Ohio Workers' Compensation

This certifies that the employer listed below participates in the Ohio State Insurance Fund as required by law. Therefore, the employer is entitled to the rights and benefits of the fund for the period specified. This certificate is only valid if premiums and assessments, including installments, are paid by the applicable due date. To verify coverage, visit www.bwc.ohio.gov, or call 1-800-644-6292.

This certificate must be conspicuously posted.

Policy number and employer
80120009

Period Specified Below
07/01/2025 to 07/01/2026

Geauga Highway Co.
14126 Main Market Rd
Hiram OH 44234-9604

www.bwc.ohio.gov

Issued by: BWC

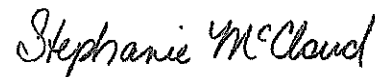

Administrator/CEO

You can reproduce this certificate as needed.

Ohio Bureau of Workers' Compensation

Required Posting

Section 4123.54 of the Ohio Revised Code requires notice of rebuttable presumption. Rebuttable presumption means an employee may dispute or prove untrue the presumption (or belief) that alcohol, marihuana or a controlled substance not prescribed by the employee's physician is the proximate cause (main reason) of the work-related injury.

The burden of proof is on the employee to prove the presence of alcohol, marihuana or a controlled substance was not the proximate cause of the work-related injury. An employee who tests positive or refuses to submit to chemical testing may be disqualified for compensation and benefits under the Workers' Compensation Act.



**Bureau of Workers'
Compensation**

You must post this language with the Certificate of Ohio Workers' Compensation.

State construction contractor look-up

Results

Policy number

80120009-0

Construction contractor status

APPROVED

Company name

Geauga Highway Co.

Construction contractor status date

4/5/2024

[Search again](#)

Note: BWC has designed this database for those responsible for ensuring that a construction contractor or subcontractor has a drug-free program that complies with HB 80 for any State of Ohio public improvement project. A contractor, subcontractor or lower-tier subcontractor in an APPROVED status has agreed to implement or has implemented a BWC-approved drug-free program (Substance Use Prevention and Recovery) which makes the company compliant with the mandate of the Ohio legislature through HB 80. While state contracting authorities are expected to review this database for the most current information, you may print this as verification of your current status.

DELINQUENT PERSONAL PROPERTY STATEMENT

Geauga Highway Co., having been awarded a contract by the City of Geneva, Ohio, hereby affirms under oath, pursuant to Ohio Revised Code Section 5719.042, that at the time the bid was submitted, my company was was not (CIRCLE ONE) charged with delinquent personal property taxes on the General Tax List of Personal Property for Ashtabula County, Ohio.

If such charge for delinquent personal property tax exists on the General Tax List of Personal Property for Ashtabula County, Ohio, the amount of such due and unpaid delinquent taxes, including due and unpaid penalties and interest shall be set forth below.

A copy of this statement shall be transmitted by the Taxing District's Fiscal Officer to the County Treasurer within thirty days of the date it is submitted. A copy of this statement shall also be incorporated into the Contract made between City of Geneva, Ohio, and Geauga Highway Co., and no payment shall be made with respect to any Contract unless such statement has been so incorporated as a part thereof.

Delinquent Personal Property Tax	\$ <u>0</u>
Penalties	\$ <u>0</u>
Interest	\$ <u>0</u>

GEAUGA HIGHWAY CO.

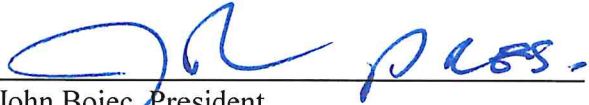

John Bojec, President

AFFIDAVIT
OF COMPLIANCE WITH OHIO REVISED CODE SECTION 3517.13

STATE OF OHIO _____

COUNTY OF Crawford _____

_____ John Boyce being duly sworn deposes and states as follows:

1. I am duly authorized to make the statements contained herein on behalf of _____ Greoga Highway Co. ("the Contracting Party").
2. The Contracting Party is a/an (select one):
 - Individual, partnership, or other unincorporated business association (including without limitation, a professional association organized under Ohio Revised Code Chapter 1787), estate, or trust
 - Corporation organized and existing under the laws of the State of Ohio
 - Labor organization
3. I hereby affirm that the Contracting Party and each of the individuals specified in R.C. 3517.13(I) (with respect to non-corporate entities and labor organizations) or R.C. 3517.13(J) (with respect to corporations) are in full compliance with the political contribution limitations set forth in R.C. 3517.13(I) and (J), as applicable.
4. I understand that a false representation on this certification will incur penalties pursuant to 3517.992(R).

Affiant further sayeth naught.

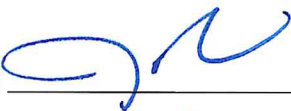
By: _____

Title: _____
Pres.

SWORN TO BEFORE ME and subscribed in my presence this 16 day of APRIL, 2026.

Notary Public

My commission expires: 2-13-28

NOTICE TO PROCEED

Project: GENEVA STREETScape IMPROVEMENTS
Phase 2 Streetscape – Appalachian Trail Community Grant Funded
Depot Street Storm Sewer – CDBG Funded

Owner: City of Geneva
44 North Forest Street
Geneva, Ohio 44041

To: Geauga Highway Co.
15651 W High St., Unit 2
Middlefield, Ohio 44062

Date: _____

You are hereby notified to commence work in accordance with the Contract. All work shall be completed by August 28, 2026.

CITY OF GENEVA

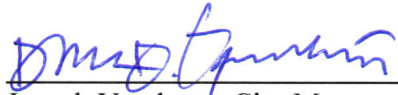

Joseph Varckette, City Manager

CERTIFICATE OF COMPLIANCE WITH FEDERAL LABOR STANDARDS PROVISIONS

I, the undersigned John Bojec _____,

the duly authorized representative of Geauga Highway Co. hereinafter referred to as the Contractor), do hereby certify that I have examined the Federal Labor Standards Provisions (HUD-4010) with related certificates and documents and all of the conditions surrounding these provisions including but not limited to the following:

1. The contractor is responsible for employing only eligible subcontractors who have certified eligibility in written contracts containing Federal Labor Standards Provisions.
2. The contractor is responsible for the payment of Federal Prevailing Wage rates by its subcontractors while performing work under this contract. If the subcontractor fails to pay the prevailing wages as specified in this contract, the prime contractor may be required to make appropriate restitution to the underpaid workers.
3. The contractor is responsible for collecting weekly certified payrolls from its subcontractors, reviewing said payrolls for compliance with the Federal Wage Rates, and forwarding same to the local government contract authority.
4. The contractor also understands that only those classifications listed in the original bid documents are applicable to this job, and no special classifications may be incorporated after contract award.

The prime contractor hereby agrees to perform all of its responsibilities in conformance with the Federal Labor Standards Provisions both diligently and affectively.

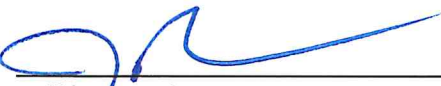
BY:  _____
(Signature)

DATE: 4/20/26 .

TITLE: President _____

COMMUNITY DEVELOPMENT BLOCK GRANT PROGRAM

CONTRACTOR'S CERTIFICATION

CONCERNING LABOR STANDARDS AND PREVAILING WAGE REQUIREMENTS

TO (Appropriate Recipient)	DATE
City of Geneva and Ashtabula County Board of Commissioners C/O	PROJECT NUMBER (If any) 0000031538PH2
	PROJECT NAME Geneva Streetscape Improvements - Depot Street Storm Sewer

1. The undersigned, having executed a contract with Geauga Highway Co. for the construction of the above-identified project, acknowledges that
 - (a) The Labor Standards Provisions are included in the aforesaid contract;
 - (b) Correction of any infractions of the aforesaid conditions, including infractions by any of his subcontractors and any lower tier subcontractors is his responsibility;

2. He certifies that
 - (a) Neither he nor any firm, partnership, or association in which he has substantial interest is designated as an ineligible contractor by the Comptroller General of the United States pursuant to Section 5.8(b) of the Regulations of the Secretary of Labor, Part 5 (29 CFR Part 5) or pursuant to Section 3(a) of the Davis-Bacon Act as amended [40 U.S.C. 276a-2(a)].
 - (b) No part of the aforementioned contract has been or will be subcontracted to any subcontractor if such subcontractor or any firm, corporation, partnership, or association in which such subcontractor has a substantial interest is designated as an ineligible contractor pursuant to any of the aforementioned regulatory or statutory provisions.

3. He agrees to obtain and forward to the aforementioned recipient within ten (10) days after the execution of any subcontract, including those executed by his subcontractors any lower tier subcontractors, a Subcontractor's Certification Concerning Labor Standards and Prevailing Wage Requirements executed by the subcontractors.

4. He certifies that
 - (a) The legal name and the business address of the undersigned is
Geauga Highway Co.
15651 W High St., Unit 2
Middlefield, OH 44062

 - (b) The undersigned is
 - (1) A single Proprietorship
 - (2) A Corporation organized in the State of Ohio
 - (3) A Partnership
 - (4) Other Organization (Describe) _____

(c) The names, titles, and addresses of the Owners, Partners, or Officers of the undersigned are

NAME	TITLE	ADDRESS
John Bojec	President	18031 Claridon Troy Rd Hiram OH 44234
Gary Helf	Secretary	12395 Fairview Warren Rd Concord Township OH 44077

(d) The names and addresses of all other persons, both natural and corporate, having a substantial interest in the undersigned, and the nature of the interest: (If none, so state)

NAME	ADDRESS	NATURE OF INTEREST
none		

(e) The names, addresses, and trade classifications of all other building construction contractors in which the undersigned has a substantial interest are (If none, so state)

NAME	ADDRESS	TRADE CLASSIFICATION
none		

4/16/26

Date

Geauga Highway Co.
(Contractor)

John Bojec, President



WARNING

U. S. CRIMINAL CODE, Section 1010, Title 15, U.S.C., provides in part: "Whoever . . . makes, presents, utters, or publishes any statement, knowing the same to be false . . . shall be fined not more than \$5,000 or imprisoned not more than two years, or both."

CERTIFICATION OF BIDDER REGARDING EQUAL EMPLOYMENT OPPORTUNITY

NAME OF PRIME CONTRACTOR
GEAUGA HIGHWAY CO.

PROJECT NUMBER (If any)
0000031538PH2

INSTRUCTIONS

This certification is required pursuant to Executive Order 11246 (30 F.R. 12319-25). The implementing rules and regulations provide that any bidder or prospective contractor, or any of their proposed subcontractors, shall state as an initial part of the bid or negotiations of the contract whether it has participated in any previous contract or subcontract subject to the equal opportunity clauses; and, if so, whether it has filed all compliance reports due under applicable instructions.

Where the certification indicates that the bidder has not filed a compliance report due under applicable instructions, such bidder shall be required to submit a compliance report within seven calendar days after bid opening. No contract shall be awarded unless such report is submitted.

CONTRACTOR'S CERTIFICATION

Name and address of Bidder (Include ZIP Code)

Geauga Highway Co.
15651 W High St., Unit 2
Middlefield, OH 44062

1. Bidder has participated in a previous contract or subcontract subject to the Equal Opportunity Clause.

Yes No

2. Compliance reports were required to be filed in connection with such contract or subcontract.

Yes No

3. Bidder has filed all compliance reports due under applicable instruction, including SF-100.

Yes No

4. Have you ever been or are you being considered for sanction due to violation of Executive Order 11246, as amended?

Yes No

NAME AND TITLE OF SIGNER (Please print or type)

John Bojec, President

SIGNATURE

DATE

Modeled after form HUD-12

CDBG.CF.4

CERTIFICATION OF NONSEGREGATED FACILITIES

The undersigned BIDDER, GEAUGA HIGHWAY CO., certifies that he does not maintain or provide for his employees any segregated facilities at any of his establishments, and that he does not permit his employees to perform their services at any location under his control where segregated facilities are maintained. The BIDDER certifies further that he will not maintain or provide for his employees any segregated facilities at any of his establishments, and that he will not permit his employees to perform their services at any location under his control where segregated facilities are maintained. The BIDDER agrees that a breach of this certification will be a violation of the Equal Opportunity clause in any contract resulting from acceptance of this bid. As used in this certification, the term "segregated facilities" means any waiting rooms, work areas, restrooms and washrooms, restaurants and other eating areas, time clocks, locker rooms and other storage or dressing areas, parking lots, drinking fountains, recreation or entertainment areas, transportation, and housing facilities provided for employees which are segregated by explicit directive or are, in fact, segregated on the basis of race, color, religion, or national origin, because of habit, local custom, or otherwise. The BIDDER agrees that (except where he has obtained identical certification from proposed subcontractors for specific time periods) he will obtain identical certifications from proposed subcontractors prior to the award of subcontractors exceeding \$10,000 which are not exempt from the provisions of the Equal Opportunity clause, and that he will retain such certifications in his files.

Note: The penalty for making false statements in offers is prescribed in 18 U.S.C. 1001.

Date: 4/16/26

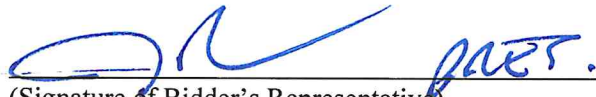

(Signature of Bidder's Representative)

John Bojec

(Printed or Typed Name of Representative)

President

(Title of Bidder's Representative)

CERTIFICATION REGARDING LOBBYING

Certification for Contracts, Grants, Loans, and Cooperative Agreements

The undersigned certifies to the best of his or her knowledge and belief that

1. No Federal appropriated funds have been paid or will be paid by or on behalf of the undersigned to any person for influencing or attempting to influence an officer or employee of any agency, a Member of Congress, an officer or employee of Congress, or an employee of a Member of Congress in connection with the awarding of any Federal contract, the making of any Federal grant, the making of any Federal loan, the entering into of any cooperative Agreement, and the extension, continuation, renewal, amendment, or modification of any Federal contract, grant, loan, or cooperative agreement.
2. If any funds other than Federal appropriated funds have been paid or will be paid to any person for influencing or attempting to influence an officer or employee of any agency, a Member of Congress, an officer or employee of Congress, in connection with this Federal contract, grant, loan, or cooperative agreement, the undersigned shall complete and submit standard Form LLL "Disclosure Form to Report Lobbying" in accordance with its instruction.
3. The undersigned shall require that the language of this certification be included in the award documents for all subawards at all tiers (including subcontracts, subgrants, and contracts under grants, loans, and cooperative agreements) and that all subrecipients shall certify and disclose accordingly.

This certification is a material representation of fact upon which reliance was placed when this transaction was made or entered into. Submission of this certification is a prerequisite for making or entering into this transaction imposed by Section 1352, Title 31, U.S. Code. Any person who fails to file the required certification shall be subject to a civil penalty of not less than \$10,000 and not more than \$100,000 for each such failure.

Signature _____

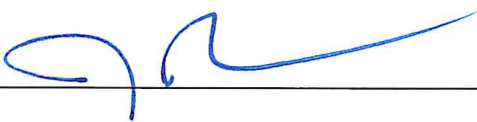

Name & Title John Bojec, President

Date _____

4/16/26

SUBCONTRACTORS

Company Name Not Applicable - No Subcontracting			Federal ID #
City & Zip Code			Amount of Contract
Payroll Officer	Telephone Number	Fax Number	Email Address

Company Name			Federal ID #
City & Zip Code			Amount of Contract
Payroll Officer	Telephone Number	Fax Number	Email Address

Company Name			Federal ID #
City & Zip Code			Amount of Contract
Payroll Officer	Telephone Number	Fax Number	Email Address

Company Name			Federal ID #
City & Zip Code			Amount of Contract
Payroll Officer	Telephone Number	Fax Number	Email Address

Company Name			Federal ID #
City & Zip Code			Amount of Contract
Payroll Officer	Telephone Number	Fax Number	Email Address

Company Name			Federal ID #
City & Zip Code			Amount of Contract
Payroll Officer	Telephone Number	Fax Number	Email Address

***Please Submit Extra Sheet if Necessary**

CURRENT TOTAL WORKFORCE BREAKDOWN

COMPANY: Geauga Highway Co.

DATE: 4/19/26

List Total Workforce (All Employees) for the Company

Job Category	Total Employees	Female	Caucasian	African American	Spanish American	American Indian	Asian	Other
Officers/ Supervisors	See Attached							
Professionals								
Technicians								
Housing/Sales/ Rental/Mgmt.								
Office/ Clerical								
Service Workers								
Journeyman								
Helpers								
Apprentices								
Trainees								
Trade:								
Trade:								
Other:								
Other:								
TOTAL:								

***List Construction Trade / Other Job Title**

Minority Compliance
03/02/26 To 04/19/26

Trade	<-TOT HRS->		<-BLACK->		<-HISPANIC->		<-ASIAN->		<-INDIAN->		<-PERCENT->		<-TOT EMP->		<-TOTMIN->	
	M	F	M	F	M	F	M	F	M	F	MIN	F	M	F	M	F
LABORERS	3621		194		2170						65.3	0.0	23		14	
OPERATORS	806	60									0.0	6.9	4	1		
Journey Workers	4426	60	194		2170						52.7	1.3	27	1	14	
Apprentices											0.0	0.0				
Trainees											0.0	0.0				
Grand Total	4426	60	194		2170						52.7	1.3	27	1	14	

Business Name Geauga Highway Co.			Date Completed 04, 20, 26
Project Name Geneva Streetscape Improvements - - Depot Street Storm Sewer			City Middlefield OH 44062
EEO Officer Brittany Bee	Telephone Number 4408344850	Fax Number 4406821208	Email Address Bid@ghwyco.com

PROPOSED PROJECT WORKFORCE BREAKDOWN

Job Category	Total Employees	Female	Caucasian	African American	Spanish American	American Indian	Asian	Other	# of positions not current occupied	# of positions to be filled with SEC 3 persons
Officers/ Supervisors	4									
Professionals	1		1							
Technicians										
Housing/Sales/ Rental/Mgmt.										
Office/ Clerical	3	2								
Service Workers										
Journeyman	28	1	12	4	6					
Helpers										
Apprentices	2		2							
Trainees										
Trade:										
Trade:										
Other:										
Other:										
TOTAL:	38	3	21	4	6					

List ONLY the Employees that will be Working on the Project

***List Construction Trade / Other Job Title**

N.A.

COMMUNITY DEVELOPMENT BLOCK GRANT PROGRAM

SUBCONTRACTOR'S CERTIFICATION

CONCERNING LABOR STANDARDS AND PREVAILING WAGE REQUIREMENTS

TO (Appropriate Recipient)	DATE
City of Geneva and Ashtabula County Board of Commissioners	PROJECT NUMBER (If any) 0000031538PH2
C/O	PROJECT NAME Geneva Streetscape Improvements - Depot Street Storm Sewer

1. The undersigned, having executed a contract with Geauga Highway Co.
for the following work:

_____ in the amount of \$_____ for the construction of the above-identified project, certifies that:

- (a) The Labor Standards provisions of the Contract for Construction are included in the aforesaid contract;
- (b) Neither he nor any firm, partnership, or association in which he has substantial interest is designated as an ineligible contractor by the Comptroller General of the United States pursuant to Section 5.8(b) of the Regulations of the Secretary of Labor, Part 5 (29 CFR Part 5) or pursuant to Section 3(a) of the Davis-Bacon Act as amended [40 U.S.C. 276a-2(a)].
- (c) No part of the aforementioned contract has been or will be subcontracted to any subcontractor if such subcontractor or any firm, corporation, partnership, or association in which such subcontractor has a substantial interest is designated as an ineligible contractor pursuant to any of the aforementioned regulatory or statutory provisions.

2. He agrees to obtain and forward to the Contractor for transmittal to the recipient within ten (10) days after the execution of any lower subcontract, a Subcontractor's Certification Concerning Labor Standards and Prevailing Wage Requirements executed by the lower tier subcontractors, in duplicate.

The workmen will report for duty on or about _____ (date).

3. He certifies that

(a) The legal name and the business address of the undersigned are

(b) The undersigned is

- _____ (1) A single Proprietorship
- _____ (2) A Corporation organized in the State of _____
- _____ (3) A Partnership
- _____ (4) Other Organization (Describe) _____

(c) The names, titles, and addresses of the Owners, Partners, or Officers of the undersigned are

NAME	TITLE	ADDRESS

(d) The names and addresses of all other persons, both natural and corporate, having a substantial interest in the undersigned, and the nature of the interest (If none, so state)

NAME	ADDRESS	NATURE OF INTEREST

(e) The names, addresses, and trade classifications of all other building construction contractors in which the undersigned has a substantial interest are (If none, so state)

NAME	ADDRESS	TRADE CLASSIFICATION

Date

(Subcontractor)

(Signature, Name & Title)

WARNING

U. S. CRIMINAL CODE, Section 1010, Title 15, U.S.C., provides in part: "Whoever . . . makes, presents, utters, or publishes any statement, knowing the same to be false . . . shall be fined not more than \$5,000 or imprisoned not more than two years, or both."

N.A.

**CERTIFICATION BY PROPOSED SUBCONTRACTOR REGARDING EQUAL
EMPLOYMENT OPPORTUNITY**

NAME OF PRIME CONTRACTOR GEAUGA HIGHWAY CO.	PROJECT NUMBER (If any) 0000031538PH2
--	--

INSTRUCTIONS

This certification is required pursuant to Executive Order 11246 (30 F.R. 12319-25). The implementing rules and regulations provide that any bidder or prospective contractor or any of their proposed subcontractors shall state as an initial part of the bid or negotiations of the contract whether it has participated in any previous contract or subcontract subject to the Equal Opportunity Clauses; and, if so, whether it has filed all compliance reports due under applicable instructions.

Where the certification indicates that the Subcontractor has not filed a compliance report due under applicable instructions, such subcontractor shall be required to submit a compliance report before the Owner approves the subcontract or permits work to begin under the subcontract.

SUBCONTRACTOR'S CERTIFICATION

Name and Address of Subcontractor (Include ZIP Code)

1. Bidder has participated in a previous contract or subcontract subject to the Equal Opportunity Clause.

_____ Yes _____ No

2. Compliance reports were required to be filed in connection with such contract or subcontract.

_____ Yes _____ No

3. Bidder has filed all compliance reports due under applicable instruction, including SF-100.

_____ Yes _____ No

4. Have you ever been or are you being considered for sanction due to violation of Executive Order 11246, as amended?

_____ Yes _____ No

NAME AND TITLE OF SIGNER (Please print or type)

SIGNATURE

DATE

CERTIFICATION OF COMPLIANCE WITH AIR AND WATER ACTS

(Applicable to Federally assisted construction contracts and related subcontracts exceeding \$100,000)

Compliance with Air and Water Acts

During the performance of this contract, the contractor and all subcontractors shall comply with the requirements of the Clean Air Act as amended, 42 USC 1857 et seq., the Federal Water Pollution Control Act as amended, 33 USC 1251 et seq., and the regulations of the Environmental Protection Agency with respect thereto at 40 CFR Part 15, as amended.

In addition to the foregoing requirements, all nonexempt contractors and subcontractors shall furnish to the Owner, the following:

1. A stipulation by the Contractor or subcontractors that any facility to be utilized in the performance of any nonexempt contract or subcontract is not listed on the List of Violating Facilities issued by the Environmental Protection Agency (EPA) pursuant to 40 CFR 15.20.
2. Agreement by the Contractor to comply with all the requirements of Section 114 of the Clean Air Act as amended, (42 USC 1857c-8) and Section 308 of the Federal Water Pollution Control Act as amended, (33 USC 1318) relating to inspection, monitoring, entry, reports, and information as well as all other requirements specified in said Section 114 and Section 308, and all regulations and guidelines issued thereunder.
3. A stipulation that as a condition for the award of the contract, prompt notice will be given of any notification received from the Director, Office of Federal Activities, EPA, indicating that a facility utilized or to be utilized for the contract is under consideration to be listed on the EPA List of Violating Facilities.
4. Agreement by the Contractor that he will include or cause to be included the criteria and requirements in paragraphs 1 through 4 of this Section in every nonexempt subcontract and requiring that the Contractor will take such action as the Government may direct as a means of enforcing such provisions.

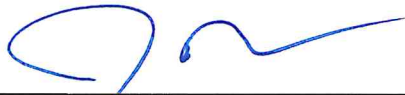

Signature

4/24/26

Date

John Bojec, President

THE OWNER OR THEIR AUTHORIZED REPRESENTATIVE SHALL INSERT THE FOLLOWING CONTRACT DOCUMENTATION IN THE EXECUTED CONTRACT:

A) FINDINGS FOR RECOVERY – ORC 9.24
(<http://ffr.ohioauditor.gov/>)

B1) CHECK FOR DEBARRED CONTRACTORS IN THE STATE OF OHIO
(<https://www.sos.state.oh.us/records/debarred-contractors/>)

**B2) CHECK FEDERAL SAM (System for Award Management) for
FEDERAL FUNDING (including sub-contractors), (if applicable)**
(<https://www.sam.gov/SAM/>)

**C) NOTIFICATION OF SURETY AND AGENT OF CONSTRUCTION
CONTRACT AWARD – ORC 9.32 (if applicable)**

**~~D) NOTIFICATION TO UTILITY COMPANIES OF COMMENCEMENT
OF CONTRACT EXECUTION – ORC 153.64 (if applicable)~~**



Office of Auditor of State
88 East Broad Street
Post Office Box 1140
Columbus, OH 43216-1140

Auditor of State - Unresolved Findings for Recovery Certified Search

(614) 466-4514
(800) 282-0370

I have searched The Auditor of State's unresolved findings for recovery database using the following criteria:

Contractor's Information:

Name: **Bojec, John**
Organization: **Geauga Highway Co.**
Date: **4/10/2026 2:03:56 PM**

This search produced the following list of **20** possible matches:

Name/Organization	Address
Anderson, John	10440 Angola Road
Briggle, John	1452 Berdan Ave.
Evans, John	143 W. Main Street
Flemon, John	4760 Gale Way
Fleshman, John	3471 Lowell Drive
Fortson, Johnny	1040 Helmsdale Road
Hazelwood, John	3280 Morse Rd., Suite 214
Holtz, John	5541 Bowman Street
Lavelle, John	
Lee, John	P.O. BOX 186
Mack, John	2840 Oak Forest Drive
Maurer, John	20 South Limestone Street, Suite 100
Osborn, John	18088 Crawmer Rd. SE
Overmier, John	591 Road 9
Rice, John	
Smith, John	1415 S. Pennsylvania Ave.
Stanforth, John	1088 Fife Avenue
Vitatoe, John	
Worley, John	86301 North Bay Road East Shore
Zimmerly, John	227 Burlington Road

The above list represents possible matches for the search criteria you entered. Please note that pursuant to ORC 9.24, only the person (which includes an organization) actually named in the finding for recovery is prohibited from being awarded a contract.

If the person you are searching for appears on this list, it means that the person has one or more findings for recovery and is prohibited from being awarded a contract described in ORC 9.24, unless one of the exceptions in that section apply.

If the person you are searching for does not appear on this list, an initialed copy of this page can serve as documentation of your compliance with ORC 9.24(E).

Please note that pursuant to ORC 9.24, it is the responsibility of the public office to verify that a person to whom it plans to award a contract does not appear in the Auditor of State's database. The Auditor of State's office is not responsible for inaccurate search results caused by user error or other circumstances beyond the Auditor of State's control.

DEBARRED CONTRACTORS

There are currently no debarred contractors.

For questions, please contact the Department of Commerce, Bureau of Wage & Hour.

State of Ohio Debarment List

State agencies given the authority to debar suppliers by the Ohio Revised Code (R.C.) are the Ohio Facilities Construction Commission (OFCC), the Ohio Department of Transportation (ODOT), the Department of Administrative Services (DAS), and the Ohio Secretary of State. Respectively, debarment authority is given to these agencies by R.C. [53.02](#), [5513.06](#), [125.25](#) (opens in new webpage). The reasons for debarment are also prescribed by these statutes.

A debarred supplier cannot participate (i.e., do any work in any capacity) in any State agency contracts until the debarment period expires. Neither the Ohio Revised Code nor the Ohio Administrative Code (OAC) establish prescribed debarment periods. Instead, these are determined on a case-by-case basis.

When conducting procurements, State agencies are required to use the Statewide Debarment List. For agencies using OhioBuys, suppliers' profiles can be referenced to determine their debarment status, plus systematic controls are in place preventing debarred vendors from doing business with State agencies. Additionally, agencies must use the [Ohio Secretary of State](#) (opens in new webpage) and the United States General Services Administration's [System for Award Management \(SAM\)](#) (opens in new webpage) list of federally debarred suppliers. State agencies are prohibited from awarding contracts, funded in whole or in part with state and/or federal funds, to any person or company on any of these lists.

Show entries per page

Vendor	Vendor ID	Address	Start Date	End Date	Debarred By
--------	-----------	---------	------------	----------	-------------

No matching records found

Showing 0 to 0 of 0 entries (filtered from 33 total entries)

[Previous](#) [Next](#)



Scheduled SAM Maintenance [Show Details](#)
Apr 3, 2026



[See All Alerts](#)

Revolutionary FAR Overhaul Impacts to SAM.gov [Show Details](#)
Aug 15, 2025



[Requests](#) [Notifications](#) [Workspace](#) [Sign Out](#)

[Home](#) [Search](#) [Data Bank](#) [Data Services](#) [Help](#)

Search

All Words

e.g. 1606N020Q02

[Search Results](#)

[Saved Searches](#)

[Actions](#)

Filter By

Keyword Search

For more information on how to use our keyword search, visit our [help guide](#)

[Simple Search](#)

[Search Editor](#)

Any Words [i](#)

All Words [i](#)

Exact Phrase [i](#)

e.g. 123456789, Smith Corp

"Geauga Highway Co." [x](#)

Classification [v](#)

Excluded Individual [v](#)

Excluded Entity [v](#)

Federal Organizations [v](#)

Exclusion Type [v](#)

Exclusion Program [v](#)

Location [v](#)

Dates [v](#)

[Reset](#) [c](#)

[Entity Information](#) [^](#)



[ities](#)

[Disaster Response Registry](#)

[Responsibility / Qualification](#)



No matches found

We couldn't find a match for your search criteria.

Please try another search or go back to previous results.

[Go Back](#)

Our Website

[About This Site](#)
[Our Community](#)
[Release Notes](#)
[System Alerts](#)

Our Partners

[Acquisition.gov](#)
[USASpending.gov](#)
[Grants.gov](#)
[More Partners](#)

Policies

[Terms of Use](#)
[Privacy Policy](#)
[Restricted Data Use](#)
[Freedom of Information Act](#)
[Accessibility](#)

Customer Service

[Help](#)
[Check Entity Status](#)
[Federal Service Desk](#)
[External Resources](#)
[Contact](#)



WARNING

This is a U.S. General Services Administration Federal Government computer system that is **"FOR OFFICIAL USE ONLY."** This system is subject to monitoring. Individuals found performing unauthorized activities are subject to disciplinary action including criminal prosecution.

This system contains Controlled Unclassified Information (CUI). All individuals viewing, reproducing or disposing of this information are required to protect it in accordance with 32 CFR Part 2002 and GSA Order CIO 2103.2 CUI Policy.

[SAM.gov](#)

An official website of the U.S. General Services Administration

April 21, 2026

Western Surety Company
151 N. Franklin Street
Chicago, IL 60606

Re: GENEVA STREETSCAPE IMPROVEMENTS
Phase 2 Streetscape – Appalachian Trail Community Grant Funded
Depot Street Storm Sewer – CDBG Funded
City of Geneva
Geauga Highway Co.

To Whom It May Concern:

In compliance with Ohio Revised Code Section 9.32, we are hereby notifying you on behalf of the City of Geneva that the City of Geneva awarded a contract for the above-referenced project to Geauga Highway Co., currently named as principal on a Bond given as surety to the City of Geneva.

Should you have any questions or require additional information, please feel free to contact our office.

Respectfully,

VERDANTAS LLC



Lene C. Hill, P.E.
City Engineer

LCH:mep

cc: Mark Arnold, Arnold Insurance Agency, Inc.

Z:\Project Files\GA-HZ\Geneva\31538 - Geneva Appalachian Community Grant Imp\Working\Bid Documents\Phase 2 - Geneva Streetscape Improvements\Contract Forms\Contract Letters.docx



Entity#: 4790158
Filing Type: CORPORATION FOR PROFIT
Original Filing Date: 12/20/2021
Location: HIRAM-
Business Name: GEAUGA HIGHWAY CO.

Status: Active
Exp. Date: -

Agent/Registrant Information

JOHN BOJEC
15651 W. HIGH STREET
MIDDLEFIELD OH 44062
12/20/2021
Active

Filings

Filing Type	Date of Filing	Document ID
DOMESTIC ARTICLES/FOR PROFIT	12/20/2021	202135402150
DOMESTIC AGENT ADDRESS CHANGE	03/19/2024	202407903850
DOMESTIC AGENT ADDRESS CHANGE	03/03/2026	202606211178

UNITED STATES OF AMERICA
STATE OF OHIO
OFFICE OF SECRETARY OF STATE

I, Frank LaRose, Secretary of State of the State of Ohio, do hereby certify that this is a list of all records approved on this business entity and in the custody of the Secretary of State.



Witness my hand and the seal of the Secretary of State at Columbus, Ohio this 10th of April, A.D. 2026

Ohio Secretary of State





DATE	DOCUMENT ID	DESCRIPTION	FILING	EXPED	PENALTY	CERT	COPY
03/03/2026	202606211178	AGENT ADDRESS CHANGE (AGA)	25.00				0

Receipt

This is not a bill. Please do not remit payment.

**HENDERSON, SCHMIDLIN, & MCGARRY CO., LPA
840 BRAINARD ROAD
HIGHLAND HEIGHTS, OH, 44143**

**S T A T E O F O H I O
C E R T I F I C A T E**

**Ohio Secretary of State, Frank LaRose
4790158**

It is hereby certified that the Secretary of State of Ohio has custody of the business records for

GEAUGA HIGHWAY CO.

and, that said business records show the filing and recording of:

Document(s)

AGENT ADDRESS CHANGE

Document No(s):

202606211178

Effective Date: 03/03/2026



United States of America
State of Ohio
Office of the Secretary of State

Witness my hand and the seal of the
Secretary of State at Columbus, Ohio
this 3rd day of March, A.D. 2026.

Ohio Secretary of State

PROJECT: Geneva Streetscape Improvements - Streetscape Phase 2 and Depot Street Storm Sewer
 OWNER: City of Geneva, OH
 PROJECT NO.: 0000031538

SORTED BY BASE BID - STREETSCAPE PHASE 2

BIDDER	BASE BID		BID TOTAL		STREETSCAPE, DEPOT STREET, & ALT A		STREETSCAPE, DEPOT STREET, & ALT B		STREETSCAPE, DEPOT STREET, & ALT A & B	
	STREETSCAPE PHASE 2	STORM SEWER	STREETSCAPE & DEPOT STREET	STREETSCAPE & DEPOT STREET	STREETSCAPE, DEPOT STREET, & ALT A	STREETSCAPE, DEPOT STREET, & ALT B	STREETSCAPE, DEPOT STREET, & ALT A & B	STREETSCAPE, DEPOT STREET, & ALT A & B	STREETSCAPE, DEPOT STREET, & ALT A & B	
Geauga Highway Company	\$829,539.35	\$147,622.00	\$977,161.35	\$977,161.35	\$1,027,161.35	\$1,025,161.35	\$1,075,161.35	\$1,075,161.35	\$1,075,161.35	
S.E.T. Inc.	\$897,109.48	\$145,439.00	\$1,042,548.48	\$1,042,548.48	\$1,082,963.48	\$1,086,473.48	\$1,126,888.48	\$1,126,888.48	\$1,126,888.48	
Eclipse Co., LLC	\$927,940.31	\$185,139.54	\$1,113,079.85	\$1,113,079.85	\$1,156,999.28	\$1,161,332.32	\$1,205,251.75	\$1,205,251.75	\$1,205,251.75	
Great Lakes Crushing, LTD	\$960,301.00	\$126,905.00	\$1,087,206.00	\$1,087,206.00	\$1,132,706.00	\$1,136,706.00	\$1,182,206.00	\$1,182,206.00	\$1,182,206.00	
Engineer's Estimate	\$950,000.00	\$153,000.00	\$1,103,000.00	\$1,103,000.00	\$1,153,000.00	\$1,153,000.00	\$1,203,000.00	\$1,203,000.00	\$1,203,000.00	

ALTERNATES	STREETSCAPE DECORTAIVE SIGN		STREETSCAPE DECORTAIVE CLOCK	
	STREETSCAPE DECORTAIVE SIGN	STREETSCAPE DECORTAIVE CLOCK	STREETSCAPE DECORTAIVE SIGN	STREETSCAPE DECORTAIVE CLOCK
Geauga Highway Company	\$50,000.00	\$48,000.00	\$43,925.00	\$49,500.00
S.E.T. Inc.	\$40,415.00	\$43,925.00	\$48,252.47	\$50,000.00
Eclipse Co., LLC	\$43,919.43	\$48,252.47	\$49,500.00	\$50,000.00
Great Lakes Crushing, LTD	\$45,500.00	\$49,500.00	\$50,000.00	\$50,000.00
Engineer's Estimate	\$50,000.00	\$50,000.00	\$50,000.00	\$50,000.00

Appalachian Community Grant Improvements
City of Geneva
Bid Opening Date: April 09, 2026
Bid Tabulation Summary
Geneva Streetscape Improvements - Phase 2 - Base Bid
Project No. 0000031538

LIST OF BIDDERS

BIDDER

- 1 Geauga Highway Company
15651 W. High Street, Unit 2
Middlefield, OH 44062
Phone number: (440) 834-4850

- 2 S.E.T. Inc.
235 East Water Street, Suite C
Lowellville, OH 444361273
Phone number: (330) 536-6724

- 3 Eclipse Co., LLC
11554 East Washington
Chagrin Falls, OH 44023
Phone number: (440) 543-3493

- 4 Great Lakes Crushing, LTD
30831 Euclid Avenue
Willowick, OH 44092
Phone number: (440) 944-5500

Appalachian Community Grant Improvements
City of Geneva
Bid Opening Date: April 09, 2026
Bid Tabulation Summary
Geneva Streetscape Improvements - Phase 2 - Base Bid
Project No. 0000031538

LIST OF TOTALS

NOTE: Bidders Informal Totals appear if different than bid tab calculated total.

	<u>Name</u>	<u>Calculated Total</u>	<u>Bidder's Informal Totals</u>
1.	Geauga Highway Company	\$829,539.35	
2.	S.E.T. Inc.	\$897,109.48	\$893,625.00
3.	Eclipse Co., LLC	\$927,940.31	\$972,940.31
4.	Great Lakes Crushing, LTD	\$960,301.00	

Appalachian Community Grant Improvements
City of Geneva
Bid Opening Date: April 09, 2026
Bid Tabulation Summary
Geneva Streetscape Improvements - Phase 2 - Base Bid
Project No. 0000031538

LIST OF ALL ITEMS

NOTE: Bidders Informal unit price or item total appear if different than bid tab calculated price.

<u>Bidders</u>	<u>Labor</u>	<u>Material</u>	<u>Calculated Unit Price</u>	<u>Bidder's Informal Unit Price</u>	<u>Calculated Line Item Total</u>	<u>Bidder's Informal Line Item Total</u>
1. 1.00 LS OF (SPC) PRECONSTRUCTION VIDEO DOCUMENTATION						
Geauga Highway Company	\$650.00	\$0.00	\$650.00		\$650.00	
S.E.T. Inc.	\$1,410.00	\$0.00	\$1,410.00		\$1,410.00	
Eclipse Co., LLC	\$825.00	\$0.00	\$825.00		\$825.00	
Great Lakes Crushing, LTD	\$400.00	\$1,600.00	\$2,000.00		\$2,000.00	
2. 1.00 LS OF (SPC) BONDS AND INSURANCES, AS PER PLAN						
Geauga Highway Company	\$60,000.00	\$0.00	\$60,000.00		\$60,000.00	
S.E.T. Inc.	\$16,500.00	\$0.00	\$16,500.00		\$16,500.00	
Eclipse Co., LLC	\$0.00	\$10,676.06	\$10,676.06		\$10,676.06	
Great Lakes Crushing, LTD	\$0.00	\$15,000.00	\$15,000.00		\$15,000.00	
3. 885.00 SY OF (202) EXCAVATION AND REMOVAL OF EXISTING PAVEMENT & BASE, AS PER PLAN						
Geauga Highway Company	\$12.50	\$0.00	\$12.50		\$11,062.50	
S.E.T. Inc.	\$24.88	\$0.00	\$24.88		\$22,018.80	
Eclipse Co., LLC	\$15.50	\$0.00	\$15.50		\$13,717.50	
Great Lakes Crushing, LTD	\$26.00	\$8.00	\$34.00		\$30,090.00	
4. 28.50 FT OF (202) CURB REMOVED, AS PER PLAN						
Geauga Highway Company	\$15.00	\$0.00	\$15.00		\$427.50	
S.E.T. Inc.	\$5.00	\$0.00	\$5.00		\$142.50	
Eclipse Co., LLC	\$11.50	\$0.00	\$11.50		\$327.75	
Great Lakes Crushing, LTD	\$30.00	\$6.00	\$36.00		\$1,026.00	
5. 396.00 FT OF (202) PIPE REMOVED, 24 INCH AND UNDER						
Geauga Highway Company	\$7.00	\$0.00	\$7.00		\$2,772.00	
S.E.T. Inc.	\$5.05	\$0.00	\$5.05		\$1,999.80	
Eclipse Co., LLC	\$33.00	\$0.00	\$33.00		\$13,068.00	
Great Lakes Crushing, LTD	\$21.00	\$12.00	\$33.00		\$13,068.00	

Appalachian Community Grant Improvements
City of Geneva
Bid Opening Date: April 09, 2026
Bid Tabulation Summary
Geneva Streetscape Improvements - Phase 2 - Base Bid
Project No. 0000031538

LIST OF ALL ITEMS

NOTE: Bidders Informal unit price or item total appear if different than bid tab calculated price.

<u>Bidders</u>	<u>Labor</u>	<u>Material</u>	<u>Calculated Unit Price</u>	<u>Bidder's Informal Unit Price</u>	<u>Calculated Line Item Total</u>	<u>Bidder's Informal Line Item Total</u>
6. 165.00 FT OF (202) STORM SEWER ABANDONED, GROUT FILLED, AS PER PLAN						
Geauga Highway Company	\$6.00	\$7.00	\$13.00		\$2,145.00	
S.E.T. Inc.	\$5.16	\$6.36	\$11.52		\$1,900.80	
Eclipse Co., LLC	\$56.00	\$0.00	\$56.00		\$9,240.00	
Great Lakes Crushing, LTD	\$16.00	\$11.00	\$27.00		\$4,455.00	
7. 1.00 EACH OF (202) MANHOLE REMOVED						
Geauga Highway Company	\$1,000.00	\$0.00	\$1,000.00		\$1,000.00	
S.E.T. Inc.	\$400.00	\$0.00	\$400.00		\$400.00	
Eclipse Co., LLC	\$4,556.50	\$0.00	\$4,556.50		\$4,556.50	
Great Lakes Crushing, LTD	\$530.00	\$331.00	\$861.00		\$861.00	
8. 7.00 EACH OF (202) CATCH BASIN REMOVED						
Geauga Highway Company	\$1,000.00	\$0.00	\$1,000.00		\$7,000.00	
S.E.T. Inc.	\$300.00	\$0.00	\$300.00		\$2,100.00	
Eclipse Co., LLC	\$1,910.50	\$0.00	\$1,910.50		\$13,373.50	
Great Lakes Crushing, LTD	\$530.00	\$68.00	\$598.00		\$4,186.00	
9. 1.00 LS OF (202) REMOVAL MISC.: MISC. SITE ITEMS						
Geauga Highway Company	\$2,000.00	\$0.00	\$2,000.00		\$2,000.00	
S.E.T. Inc.	\$5,000.00	\$0.00	\$5,000.00		\$5,000.00	
Eclipse Co., LLC	\$1,408.50	\$0.00	\$1,408.50		\$1,408.50	
Great Lakes Crushing, LTD	\$8,301.57	\$1,031.43	\$9,333.00		\$9,333.00	
10. 1.00 LS OF (203) EMBANKMENT, AS PER PLAN						
Geauga Highway Company	\$4,000.00	\$1,000.00	\$5,000.00		\$5,000.00	
S.E.T. Inc.	\$5,400.00	\$1,680.00	\$7,080.00		\$7,080.00	
Eclipse Co., LLC	\$3,876.60	\$2,584.40	\$6,461.00		\$6,461.00	
Great Lakes Crushing, LTD	\$12,338.78	\$8,592.22	\$20,931.00		\$20,931.00	

Appalachian Community Grant Improvements
City of Geneva
Bid Opening Date: April 09, 2026
Bid Tabulation Summary
Geneva Streetscape Improvements - Phase 2 - Base Bid
Project No. 0000031538

LIST OF ALL ITEMS

NOTE: Bidders Informal unit price or item total appear if different than bid tab calculated price.

<u>Bidders</u>	<u>Labor</u>	<u>Material</u>	<u>Calculated Unit Price</u>	<u>Bidder's Informal Unit Price</u>	<u>Calculated Line Item Total</u>	<u>Bidder's Informal Line Item Total</u>
11. 1.00 EACH OF (SPC) SPECIAL - BIORETENTION CELL, AS PER PLAN						
Geauga Highway Company	\$20,000.00	\$10,000.00	\$30,000.00		\$30,000.00	
S.E.T. Inc.	\$27,855.00	\$24,242.50	\$52,097.50		\$52,097.50	
Eclipse Co., LLC	\$3,296.10	\$2,197.40	\$5,493.50	\$50,493.50	\$5,493.50	\$50,493.50
Great Lakes Crushing, LTD	\$42,123.00	\$27,692.00	\$69,815.00		\$69,815.00	
12. 75.00 CY OF (251) PARTIAL DEPTH PAVEMENT REPAIR, AS PER PLAN						
Geauga Highway Company	\$20.00	\$20.00	\$40.00		\$3,000.00	
S.E.T. Inc.	\$236.60	\$195.00	\$431.60		\$32,370.00	
Eclipse Co., LLC	\$234.90	\$156.60	\$391.50		\$29,362.50	
Great Lakes Crushing, LTD	\$135.00	\$250.00	\$385.00		\$28,875.00	
13. 75.00 CY OF (253) PAVEMENT REPAIR, AS PER PLAN						
Geauga Highway Company	\$200.00	\$160.00	\$360.00		\$27,000.00	
S.E.T. Inc.	\$235.40	\$205.00	\$440.40		\$33,030.00	
Eclipse Co., LLC	\$240.30	\$160.20	\$400.50		\$30,037.50	
Great Lakes Crushing, LTD	\$100.00	\$403.00	\$503.00		\$37,725.00	
14. 23.00 SY OF (SPC) TYPE "C" PAVEMENT REPLACEMENT (ASPHALT), ROADWAY, AS PER PLAN						
Geauga Highway Company	\$50.00	\$40.00	\$90.00		\$2,070.00	
S.E.T. Inc.	\$83.10	\$65.00	\$148.10		\$3,406.30	
Eclipse Co., LLC	\$143.70	\$95.80	\$239.50		\$5,508.50	
Great Lakes Crushing, LTD	\$30.00	\$122.00	\$152.00		\$3,496.00	
15. 5,327.00 SY OF (254) PAVEMENT PLANING, ASPHALT CONCRETE, AS PER PLAN						
Geauga Highway Company	\$2.55	\$0.00	\$2.55		\$13,583.85	
S.E.T. Inc.	\$5.94	\$0.00	\$5.94		\$31,642.38	
Eclipse Co., LLC	\$3.60	\$2.40	\$6.00		\$31,962.00	
Great Lakes Crushing, LTD	\$2.00	\$4.00	\$6.00		\$31,962.00	

Appalachian Community Grant Improvements
City of Geneva
Bid Opening Date: April 09, 2026
Bid Tabulation Summary
Geneva Streetscape Improvements - Phase 2 - Base Bid
Project No. 0000031538

LIST OF ALL ITEMS

NOTE: Bidders Informal unit price or item total appear if different than bid tab calculated price.

<u>Bidders</u>	<u>Labor</u>	<u>Material</u>	<u>Calculated Unit Price</u>	<u>Bidder's Informal Unit Price</u>	<u>Calculated Line Item Total</u>	<u>Bidder's Informal Line Item Total</u>
16. 2,043.00 FT OF (255) FULL DEPTH PAVEMENT SAWING, AS PER PLAN						
Geauga Highway Company	\$3.50	\$0.00	\$3.50		\$7,150.50	
S.E.T. Inc.	\$2.20	\$0.00	\$2.20		\$4,494.60	
Eclipse Co., LLC	\$2.10	\$1.40	\$3.50		\$7,150.50	
Great Lakes Crushing, LTD	\$3.00	\$3.00	\$6.00		\$12,258.00	
17. 70.00 CY OF (301) ASPHALT CONCRETE BASE, PG64-22, AS PER PLAN						
Geauga Highway Company	\$200.00	\$100.00	\$300.00		\$21,000.00	
S.E.T. Inc.	\$110.00	\$165.00	\$275.00		\$19,250.00	
Eclipse Co., LLC	\$165.00	\$110.00	\$275.00		\$19,250.00	
Great Lakes Crushing, LTD	\$100.00	\$245.00	\$345.00		\$24,150.00	
18. 480.00 GAL OF (407) TACK COAT						
Geauga Highway Company	\$2.00	\$1.50	\$3.50		\$1,680.00	
S.E.T. Inc.	\$2.38	\$2.50	\$4.88		\$2,342.40	
Eclipse Co., LLC	\$2.70	\$1.80	\$4.50		\$2,160.00	
Great Lakes Crushing, LTD	\$2.00	\$2.00	\$4.00		\$1,920.00	
19. 370.00 CY OF (441) ASPHALT CONCRETE INTERMEDIATE COURSE, TYPE 1, (448), VARIABLE THICKNESS, AS PER PLAN						
Geauga Highway Company	\$100.00	\$112.00	\$212.00		\$78,440.00	
S.E.T. Inc.	\$105.90	\$146.00	\$251.90		\$93,203.00	
Eclipse Co., LLC	\$151.20	\$100.80	\$252.00		\$93,240.00	
Great Lakes Crushing, LTD	\$100.00	\$202.00	\$302.00		\$111,740.00	
20. 222.00 CY OF (448) ASPHALT CONCRETE SURFACE COURSE, TYPE 1, PG64-22, AS PER PLAN						
Geauga Highway Company	\$100.00	\$150.00	\$250.00		\$55,500.00	
S.E.T. Inc.	\$123.00	\$152.00	\$275.00		\$61,050.00	
Eclipse Co., LLC	\$165.00	\$110.00	\$275.00		\$61,050.00	
Great Lakes Crushing, LTD	\$100.00	\$230.00	\$330.00		\$73,260.00	

Appalachian Community Grant Improvements
City of Geneva
Bid Opening Date: April 09, 2026
Bid Tabulation Summary
Geneva Streetscape Improvements - Phase 2 - Base Bid
Project No. 0000031538

LIST OF ALL ITEMS

NOTE: Bidders Informal unit price or item total appear if different than bid tab calculated price.

<u>Bidders</u>	<u>Labor</u>	<u>Material</u>	<u>Calculated Unit Price</u>	<u>Bidder's Informal Unit Price</u>	<u>Calculated Line Item Total</u>	<u>Bidder's Informal Line Item Total</u>
21. 36.00 SY OF (451) 8 INCH REINFORCED CONCRETE DRIVES AND APRONS, CLASS QCMS, INCLUDING INTEGRAL COLOR, AS PE						
Geauga Highway Company	\$100.00	\$60.00	\$160.00		\$5,760.00	
S.E.T. Inc.	\$190.00	\$10.62	\$200.62		\$7,222.32	
Eclipse Co., LLC	\$212.40	\$141.60	\$354.00		\$12,744.00	
Great Lakes Crushing, LTD	\$112.00	\$93.00	\$205.00		\$7,380.00	
22. 272.00 SF OF (608) 4 INCH CONCRETE WALK, AS PER PLAN						
Geauga Highway Company	\$6.00	\$7.00	\$13.00		\$3,536.00	
S.E.T. Inc.	\$23.58	\$15.00	\$38.58		\$10,493.76	
Eclipse Co., LLC	\$17.70	\$11.80	\$29.50		\$8,024.00	
Great Lakes Crushing, LTD	\$6.50	\$5.50	\$12.00		\$3,264.00	
23. 149.00 SF OF (608) CURB RAMP, AS PER PLAN						
Geauga Highway Company	\$10.00	\$13.00	\$23.00		\$3,427.00	
S.E.T. Inc.	\$37.61	\$0.86	\$38.47		\$5,732.03	
Eclipse Co., LLC	\$17.10	\$11.40	\$28.50		\$4,246.50	
Great Lakes Crushing, LTD	\$16.20	\$9.80	\$26.00		\$3,874.00	
24. 30.00 SF OF (608) DETECTABLE WARNING, AS PER PLAN						
Geauga Highway Company	\$15.00	\$15.00	\$30.00		\$900.00	
S.E.T. Inc.	\$80.00	\$85.00	\$165.00		\$4,950.00	
Eclipse Co., LLC	\$36.30	\$24.20	\$60.50		\$1,815.00	
Great Lakes Crushing, LTD	\$39.00	\$50.00	\$89.00		\$2,670.00	
25. 1,078.00 FT OF (609) CURB, TYPE 6, AS PER PLAN						
Geauga Highway Company	\$15.00	\$15.00	\$30.00		\$32,340.00	
S.E.T. Inc.	\$26.80	\$15.00	\$41.80		\$45,060.40	
Eclipse Co., LLC	\$23.70	\$15.80	\$39.50		\$42,581.00	
Great Lakes Crushing, LTD	\$32.85	\$9.15	\$42.00		\$45,276.00	

Appalachian Community Grant Improvements
 City of Geneva
 Bid Opening Date: April 09, 2026
 Bid Tabulation Summary
 Geneva Streetscape Improvements - Phase 2 - Base Bid
 Project No. 0000031538

LIST OF ALL ITEMS

NOTE: Bidders Informal unit price or item total appear if different than bid tab calculated price.

Bidders	Labor	Material	Calculated Unit Price	Bidder's Informal Unit Price	Calculated Line Item Total	Bidder's Informal Line Item Total
26. 82.00 FT OF (SPC) CURB, MISC.: FLUSH CURB, AS PER PLAN						
Geauga Highway Company	\$15.00	\$15.00	\$30.00		\$2,460.00	
S.E.T. Inc.	\$46.80	\$5.25	\$52.05		\$4,268.10	
Eclipse Co., LLC	\$31.20	\$20.80	\$52.00		\$4,264.00	
Great Lakes Crushing, LTD	\$32.85	\$9.15	\$42.00		\$3,444.00	
27. 189.00 FT OF (611) 12" CONDUIT, TYPE B, AS PER PLAN						
Geauga Highway Company	\$70.00	\$45.00	\$115.00		\$21,735.00	
S.E.T. Inc.	\$54.60	\$33.94	\$88.54		\$16,734.06	
Eclipse Co., LLC	\$69.00	\$46.00	\$115.00		\$21,735.00	
Great Lakes Crushing, LTD	\$44.00	\$61.00	\$105.00		\$19,845.00	
28. 316.00 FT OF (611) 18" CONDUIT, TYPE B, AS PER PLAN						
Geauga Highway Company	\$85.00	\$55.00	\$140.00		\$44,240.00	
S.E.T. Inc.	\$76.74	\$121.32	\$198.06		\$62,586.96	
Eclipse Co., LLC	\$146.70	\$97.80	\$244.50		\$77,262.00	
Great Lakes Crushing, LTD	\$44.00	\$85.00	\$129.00		\$40,764.00	
29. 2.00 EACH OF (611) CONDUIT, MISC.: CONNECTION OF CONDUIT TO EXISTING DRAINAGE STRUCTURE						
Geauga Highway Company	\$1,300.00	\$100.00	\$1,400.00		\$2,800.00	
S.E.T. Inc.	\$1,100.00	\$105.00	\$1,205.00		\$2,410.00	
Eclipse Co., LLC	\$794.40	\$529.60	\$1,324.00		\$2,648.00	
Great Lakes Crushing, LTD	\$1,324.00	\$637.00	\$1,961.00		\$3,922.00	
30. 189.00 FT OF (611) 8 INCH - 15 INCH CONDUIT INTERNAL TELEVISION INSPECTION, INCLUDING LIGHT CLEANING, AS PER PLAN						
Geauga Highway Company	\$15.00	\$0.00	\$15.00		\$2,835.00	
S.E.T. Inc.	\$7.00	\$0.00	\$7.00		\$1,323.00	
Eclipse Co., LLC	\$8.70	\$5.80	\$14.50		\$2,740.50	
Great Lakes Crushing, LTD	\$8.00	\$11.00	\$19.00		\$3,591.00	

Appalachian Community Grant Improvements
 City of Geneva
 Bid Opening Date: April 09, 2026
 Bid Tabulation Summary
 Geneva Streetscape Improvements - Phase 2 - Base Bid
 Project No. 0000031538

LIST OF ALL ITEMS

NOTE: Bidders Informal unit price or item total appear if different than bid tab calculated price.

	<u>Bidders</u>	<u>Labor</u>	<u>Material</u>	<u>Calculated Unit Price</u>	<u>Bidder's Informal Unit Price</u>	<u>Calculated Line Item Total</u>	<u>Bidder's Informal Line Item Total</u>
31.	316.00 FT OF (611) 18 INCH - 24 INCH CONDUIT INTERNAL TELEVISION INSPECTION, INCLUDING LIGHT CLEANING, AS PER PI						
	Geauga Highway Company	\$20.00	\$0.00	\$20.00		\$6,320.00	
	S.E.T. Inc.	\$7.00	\$0.00	\$7.00		\$2,212.00	
	Eclipse Co., LLC	\$8.70	\$5.80	\$14.50		\$4,582.00	
	Great Lakes Crushing, LTD	\$8.00	\$11.00	\$19.00		\$6,004.00	
32.	6.00 EACH OF (611) CATCH BASIN, NO. 2-2B, AS PER PLAN						
	Geauga Highway Company	\$2,000.00	\$1,500.00	\$3,500.00		\$21,000.00	
	S.E.T. Inc.	\$1,102.80	\$1,375.32	\$2,478.12		\$14,868.72	
	Eclipse Co., LLC	\$2,445.00	\$1,630.00	\$4,075.00		\$24,450.00	
	Great Lakes Crushing, LTD	\$3,500.00	\$2,168.00	\$5,668.00		\$34,008.00	
33.	1.00 EACH OF (611) CATCH BASIN CURB INLET, AS PER PLAN						
	Geauga Highway Company	\$2,000.00	\$2,000.00	\$4,000.00		\$4,000.00	
	S.E.T. Inc.	\$1,102.80	\$1,424.33	\$2,527.13		\$2,527.13	
	Eclipse Co., LLC	\$2,539.50	\$1,693.00	\$4,232.50		\$4,232.50	
	Great Lakes Crushing, LTD	\$3,500.00	\$2,661.00	\$6,161.00		\$6,161.00	
34.	2.00 EACH OF (611) 48 INCH STORM MANHOLE, AS PER PLAN						
	Geauga Highway Company	\$2,000.00	\$2,200.00	\$4,200.00		\$8,400.00	
	S.E.T. Inc.	\$1,320.40	\$2,243.33	\$3,563.73		\$7,127.46	
	Eclipse Co., LLC	\$5,133.30	\$3,422.20	\$8,555.50		\$17,111.00	
	Great Lakes Crushing, LTD	\$3,500.00	\$3,421.00	\$6,921.00		\$13,842.00	
35.	1.00 EACH OF (611) MANHOLE ADJUSTED TO GRADE, AS PER PLAN						
	Geauga Highway Company	\$900.00	\$200.00	\$1,100.00		\$1,100.00	
	S.E.T. Inc.	\$925.00	\$575.00	\$1,500.00		\$1,500.00	
	Eclipse Co., LLC	\$697.80	\$465.20	\$1,163.00		\$1,163.00	
	Great Lakes Crushing, LTD	\$1,060.00	\$318.00	\$1,378.00		\$1,378.00	

Appalachian Community Grant Improvements
City of Geneva
Bid Opening Date: April 09, 2026
Bid Tabulation Summary
Geneva Streetscape Improvements - Phase 2 - Base Bid
Project No. 0000031538

LIST OF ALL ITEMS

NOTE: Bidders Informal unit price or item total appear if different than bid tab calculated price.

<u>Bidders</u>	<u>Labor</u>	<u>Material</u>	<u>Calculated Unit Price</u>	<u>Bidder's Informal Unit Price</u>	<u>Calculated Line Item Total</u>	<u>Bidder's Informal Line Item Total</u>
36. 1.00 LS OF (614) MAINTAINING TRAFFIC						
Geauga Highway Company	\$120,000.00	\$0.00	\$120,000.00		\$120,000.00	
S.E.T. Inc.	\$12,400.00	\$0.00	\$12,400.00		\$12,400.00	
Eclipse Co., LLC	\$49,100.10	\$32,733.40	\$81,833.50		\$81,833.50	
Great Lakes Crushing, LTD	\$8,000.00	\$5,375.00	\$13,375.00		\$13,375.00	
37. 1.00 LS OF (623) CONSTRUCTION LAYOUT STAKES AND SURVEYING, AS PER PLAN						
Geauga Highway Company	\$5,000.00	\$0.00	\$5,000.00		\$5,000.00	
S.E.T. Inc.	\$29,000.00	\$0.00	\$29,000.00		\$29,000.00	
Eclipse Co., LLC	\$4,977.30	\$3,318.20	\$8,295.50		\$8,295.50	
Great Lakes Crushing, LTD	\$4,000.00	\$2,800.00	\$6,800.00		\$6,800.00	
38. 1.00 LS OF (624) MOBILIZATION						
Geauga Highway Company	\$5,000.00	\$0.00	\$5,000.00		\$5,000.00	
S.E.T. Inc.	\$75,685.00	\$0.00	\$75,685.00		\$75,685.00	
Eclipse Co., LLC	\$40,761.60	\$27,174.40	\$67,936.00		\$67,936.00	
Great Lakes Crushing, LTD	\$18,500.00	\$21,500.00	\$40,000.00		\$40,000.00	
39. 20.00 EACH OF (630) SIGN, FLAT SHEET, WITH MOUNTING POST						
Geauga Highway Company	\$100.00	\$125.00	\$225.00		\$4,500.00	
S.E.T. Inc.	\$370.00	\$125.00	\$495.00		\$9,900.00	
Eclipse Co., LLC	\$296.10	\$197.40	\$493.50		\$9,870.00	
Great Lakes Crushing, LTD	\$50.00	\$600.00	\$650.00		\$13,000.00	
40. 1.00 EACH OF (638) 6 INCH FIRE HYDRANT ASSEMBLY, INCLUDING 6 INCH VALVE AND VALVE BOX, TYPE A, AS PER PLAN						
Geauga Highway Company	\$5,000.00	\$4,000.00	\$9,000.00		\$9,000.00	
S.E.T. Inc.	\$2,000.00	\$5,833.80	\$7,833.80		\$7,833.80	
Eclipse Co., LLC	\$4,824.30	\$3,216.20	\$8,040.50		\$8,040.50	
Great Lakes Crushing, LTD	\$2,500.00	\$12,500.00	\$15,000.00		\$15,000.00	

Appalachian Community Grant Improvements
City of Geneva
Bid Opening Date: April 09, 2026
Bid Tabulation Summary
Geneva Streetscape Improvements - Phase 2 - Base Bid
Project No. 0000031538

LIST OF ALL ITEMS

NOTE: Bidders Informal unit price or item total appear if different than bid tab calculated price.

<u>Bidders</u>	<u>Labor</u>	<u>Material</u>	<u>Calculated Unit Price</u>	<u>Bidder's Informal Unit Price</u>	<u>Calculated Line Item Total</u>	<u>Bidder's Informal Line Item Total</u>
41. 1.00 EACH OF (638) FIRE HYDRANT & VALVE BOX REMOVED AND DISPOSED, AS PER PLAN						
Geauga Highway Company	\$1,800.00	\$200.00	\$2,000.00		\$2,000.00	
S.E.T. Inc.	\$750.00	\$0.00	\$750.00		\$750.00	
Eclipse Co., LLC	\$330.00	\$220.00	\$550.00		\$550.00	
Great Lakes Crushing, LTD	\$1,100.00	\$160.00	\$1,260.00		\$1,260.00	
42. 1.00 LS OF (642) TRAFFIC PAINT, AS PER PLAN						
Geauga Highway Company	\$3,000.00	\$4,000.00	\$7,000.00		\$7,000.00	
S.E.T. Inc.	\$8,700.00	\$10,000.00	\$18,700.00		\$18,700.00	
Eclipse Co., LLC	\$10,956.30	\$7,304.20	\$18,260.50		\$18,260.50	
Great Lakes Crushing, LTD	\$8,000.00	\$15,250.00	\$23,250.00		\$23,250.00	
43. 96.00 CY OF (659) TOPSOIL, AS PER PLAN						
Geauga Highway Company	\$40.00	\$40.00	\$80.00		\$7,680.00	
S.E.T. Inc.	\$20.00	\$47.25	\$67.25		\$6,456.00	
Eclipse Co., LLC	\$51.30	\$34.20	\$85.50		\$8,208.00	
Great Lakes Crushing, LTD	\$18.00	\$22.00	\$40.00		\$3,840.00	
44. 1.00 LS OF (659) SEEDING AND MULCHING, AS PER PLAN						
Geauga Highway Company	\$3,000.00	\$3,000.00	\$6,000.00		\$6,000.00	
S.E.T. Inc.	\$3,000.00	\$3,150.00	\$6,150.00		\$6,150.00	
Eclipse Co., LLC	\$2,199.00	\$1,466.00	\$3,665.00		\$3,665.00	
Great Lakes Crushing, LTD	\$2,500.00	\$5,800.00	\$8,300.00		\$8,300.00	
45. 11.00 CY OF (661) MULCH, AS PER PLAN						
Geauga Highway Company	\$100.00	\$100.00	\$200.00		\$2,200.00	
S.E.T. Inc.	\$50.00	\$78.75	\$128.75		\$1,416.25	
Eclipse Co., LLC	\$127.50	\$85.00	\$212.50		\$2,337.50	
Great Lakes Crushing, LTD	\$31.00	\$31.00	\$62.00		\$682.00	

Appalachian Community Grant Improvements
City of Geneva
Bid Opening Date: April 09, 2026
Bid Tabulation Summary
Geneva Streetscape Improvements - Phase 2 - Base Bid
Project No. 0000031538

LIST OF ALL ITEMS

NOTE: Bidders Informal unit price or item total appear if different than bid tab calculated price.

<u>Bidders</u>	<u>Labor</u>	<u>Material</u>	<u>Calculated Unit Price</u>	<u>Bidder's Informal Unit Price</u>	<u>Calculated Line Item Total</u>	<u>Bidder's Informal Line Item Total</u>
46. 7.00 CY OF (661) STONE MULCH, AS PER PLAN						
Geauga Highway Company	\$200.00	\$200.00	\$400.00		\$2,800.00	
S.E.T. Inc.	\$217.14	\$74.99	\$292.13		\$2,044.91	
Eclipse Co., LLC	\$176.70	\$117.80	\$294.50		\$2,061.50	
Great Lakes Crushing, LTD	\$31.00	\$65.00	\$96.00		\$672.00	
47. 44.00 EACH OF (661) PERENNIALS						
Geauga Highway Company	\$50.00	\$50.00	\$100.00		\$4,400.00	
S.E.T. Inc.	\$50.00	\$42.00	\$92.00		\$4,048.00	
Eclipse Co., LLC	\$19.80	\$13.20	\$33.00		\$1,452.00	
Great Lakes Crushing, LTD	\$10.00	\$21.00	\$31.00		\$1,364.00	
48. 9.00 EACH OF (661) DECIDUOUS SHRUB, 18 INCH HEIGHT						
Geauga Highway Company	\$100.00	\$75.00	\$175.00		\$1,575.00	
S.E.T. Inc.	\$75.00	\$73.50	\$148.50		\$1,336.50	
Eclipse Co., LLC	\$49.50	\$33.00	\$82.50		\$742.50	
Great Lakes Crushing, LTD	\$10.00	\$52.00	\$62.00		\$558.00	
49. 9.00 EACH OF (661) EVERGREEN SHRUB, 12 INCH HEIGHT						
Geauga Highway Company	\$100.00	\$50.00	\$150.00		\$1,350.00	
S.E.T. Inc.	\$75.00	\$52.50	\$127.50		\$1,147.50	
Eclipse Co., LLC	\$49.50	\$33.00	\$82.50		\$742.50	
Great Lakes Crushing, LTD	\$10.00	\$45.00	\$55.00		\$495.00	
50. 18.00 EACH OF (661) DECIDUOUS TREE, 1-1/2 INCH CALIPER						
Geauga Highway Company	\$1,200.00	\$1,000.00	\$2,200.00		\$39,600.00	
S.E.T. Inc.	\$600.00	\$315.00	\$915.00		\$16,470.00	
Eclipse Co., LLC	\$264.00	\$176.00	\$440.00		\$7,920.00	
Great Lakes Crushing, LTD	\$50.00	\$362.00	\$412.00		\$7,416.00	

Appalachian Community Grant Improvements
 City of Geneva
 Bid Opening Date: April 09, 2026
 Bid Tabulation Summary
 Geneva Streetscape Improvements - Phase 2 - Base Bid
 Project No. 0000031538

LIST OF ALL ITEMS

NOTE: Bidders Informal unit price or item total appear if different than bid tab calculated price.

<u>Bidders</u>	<u>Labor</u>	<u>Material</u>	<u>Calculated Unit Price</u>	<u>Bidder's Informal Unit Price</u>	<u>Calculated Line Item Total</u>	<u>Bidder's Informal Line Item Total</u>
51. 5.00 EACH OF (661) DECIDUOUS TREE, 2 INCH CALIPER						
Geauga Highway Company	\$1,500.00	\$1,000.00	\$2,500.00		\$12,500.00	
S.E.T. Inc.	\$500.00	\$157.50	\$657.50		\$3,287.50	
Eclipse Co., LLC	\$330.00	\$220.00	\$550.00		\$2,750.00	
Great Lakes Crushing, LTD	\$50.00	\$465.00	\$515.00		\$2,575.00	
52. 16.00 EACH OF (661) EVERGREEN TREE, 5' HEIGHT						
Geauga Highway Company	\$100.00	\$175.00	\$275.00		\$4,400.00	
S.E.T. Inc.	\$500.00	\$210.00	\$710.00		\$11,360.00	
Eclipse Co., LLC	\$330.00	\$220.00	\$550.00		\$8,800.00	
Great Lakes Crushing, LTD	\$50.00	\$465.00	\$515.00		\$8,240.00	
53. 1.00 LS OF (SPC) TEMPORARY SEDIMENT AND EROSION CONTROL, AS PER PLAN						
Geauga Highway Company	\$2,000.00	\$200.00	\$2,200.00		\$2,200.00	
S.E.T. Inc.	\$7,200.00	\$1,470.00	\$8,670.00		\$8,670.00	
Eclipse Co., LLC	\$3,605.10	\$2,403.40	\$6,008.50		\$6,008.50	
Great Lakes Crushing, LTD	\$10,000.00	\$11,900.00	\$21,900.00		\$21,900.00	
54. 1.00 LS OF (SPC) CONTINGENCY/DISCRETIONARY ALLOWANCE						
Geauga Highway Company	\$100,000.00	\$0.00	\$100,000.00		\$100,000.00	
S.E.T. Inc.	\$100,000.00	\$0.00	\$100,000.00		\$100,000.00	
Eclipse Co., LLC	\$100,000.00	\$0.00	\$100,000.00		\$100,000.00	
Great Lakes Crushing, LTD	\$100,000.00	\$0.00	\$100,000.00		\$100,000.00	

Appalachian Community Grant Improvements
City of Geneva
Bid Opening Date: April 09, 2026
Bid Tabulation Summary
Geneva Streetscape Improvements - Phase 2 - Alternate A - Decorative Sign
Project No. 0000031538

LIST OF BIDDERS

BIDDER

- 1 S.E.T. Inc.
235 East Water Street, Suite C
Lowellville, OH 444361273
Phone number: (330) 536-6724

- 2 Eclipse Co., LLC
11554 East Washington
Chagrin Falls, OH 44023
Phone number: (440) 543-3493

- 3 Great Lakes Crushing, LTD
30831 Euclid Avenue
Willowick, OH 44092
Phone number: (440) 944-5500

- 4 Geauga Highway Company
15651 W. High Street, Unit 2
Middlefield, OH 44062
Phone number: (440) 834-4850

Appalachian Community Grant Improvements
City of Geneva
Bid Opening Date: April 09, 2026
Bid Tabulation Summary
Geneva Streetscape Improvements - Phase 2 - Alternate A - Decorative Sign
Project No. 0000031538

LIST OF TOTALS

NOTE: Bidders Informal Totals appear if different than bid tab calculated total.

	<u>Name</u>	<u>Calculated Total</u>	<u>Bidder's Informal Totals</u>
1.	S.E.T. Inc.	\$40,415.00	
2.	Eclipse Co., LLC	\$43,919.43	
3.	Great Lakes Crushing, LTD	\$45,500.00	
4.	Geauga Highway Company	\$50,000.00	

Appalachian Community Grant Improvements
City of Geneva
Bid Opening Date: April 09, 2026
Bid Tabulation Summary
Geneva Streetscape Improvements - Phase 2 - Alternate A - Decorative Sign
Project No. 0000031538

LIST OF ALL ITEMS
NOTE: Bidders Informal unit price or item total appear if different than bid tab calculated price.

<u>Bidders</u>	<u>Labor</u>	<u>Material</u>	<u>Calculated Unit Price</u>	<u>Bidder's Informal Unit Price</u>	<u>Calculated Line Item Total</u>	<u>Bidder's Informal Line Item Total</u>
1. 1.00 LS OF (SPC) BONDS AND INSURANCES, AS PER PLAN						
S.E.T. Inc.	\$500.00	\$0.00	\$500.00		\$500.00	
Eclipse Co., LLC	\$0.00	\$481.93	\$481.93		\$481.93	
Great Lakes Crushing, LTD	\$0.00	\$500.00	\$500.00		\$500.00	
Geauga Highway Company	\$1,000.00	\$0.00	\$1,000.00		\$1,000.00	
2. 1.00 EACH OF (SPC) DECORATIVE SIGN, AS PER PLAN						
S.E.T. Inc.	\$18,110.00	\$21,805.00	\$39,915.00		\$39,915.00	
Eclipse Co., LLC	\$26,062.50	\$17,375.00	\$43,437.50		\$43,437.50	
Great Lakes Crushing, LTD	\$15,000.00	\$30,000.00	\$45,000.00		\$45,000.00	
Geauga Highway Company	\$49,000.00	\$0.00	\$49,000.00		\$49,000.00	

Appalachian Community Grant Improvements
City of Geneva
Bid Opening Date: April 09, 2026
Bid Tabulation Summary
Geneva Streetscape Improvements - Phase 2 - Alternate B - Decorative Clock
Project No. 0000031538

LIST OF BIDDERS

BIDDER

- 1 S.E.T. Inc.
235 East Water Street, Suite C
Lowellville, OH 444361273
Phone number: (330) 536-6724

- 2 Geauga Highway Company
15651 W. High Street, Unit 2
Middlefield, OH 44062
Phone number: (440) 834-4850

- 3 Eclipse Co., LLC
11554 East Washington
Chagrin Falls, OH 44023
Phone number: (440) 543-3493

- 4 Great Lakes Crushing, LTD
30831 Euclid Avenue
Willowick, OH 44092
Phone number: (440) 944-5500

Appalachian Community Grant Improvements
City of Geneva
Bid Opening Date: April 09, 2026
Bid Tabulation Summary
Geneva Streetscape Improvements - Phase 2 - Alternate B - Decorative Clock
Project No. 0000031538

LIST OF TOTALS

NOTE: Bidders Informal Totals appear if different than bid tab calculated total.

	<u>Name</u>	<u>Calculated Total</u>	<u>Bidder's Informal Totals</u>
1.	S.E.T. Inc.	\$43,925.00	
2.	Geauga Highway Company	\$48,000.00	
3.	Eclipse Co., LLC	\$48,252.47	
4.	Great Lakes Crushing, LTD	\$49,500.00	

Appalachian Community Grant Improvements
City of Geneva
Bid Opening Date: April 09, 2026
Bid Tabulation Summary
Geneva Streetscape Improvements - Phase 2 - Alternate B - Decorative Clock
Project No. 0000031538

LIST OF ALL ITEMS

NOTE: Bidders Informal unit price or item total appear if different than bid tab calculated price.

<u>Bidders</u>	<u>Labor</u>	<u>Material</u>	<u>Calculated Unit Price</u>	<u>Bidder's Informal Unit Price</u>	<u>Calculated Line Item Total</u>	<u>Bidder's Informal Line Item Total</u>
1. 1.00 LS OF (SPC) BONDS AND INSURANCES, AS PER PLAN						
S.E.T. Inc.	\$500.00	\$0.00	\$500.00		\$500.00	
Geauga Highway Company	\$1,000.00	\$0.00	\$1,000.00		\$1,000.00	
Eclipse Co., LLC	\$0.00	\$529.47	\$529.47		\$529.47	
Great Lakes Crushing, LTD	\$0.00	\$500.00	\$500.00		\$500.00	
2. 1.00 EACH OF (SPC) DECORATIVE CLOCK, AS PER PLAN						
S.E.T. Inc.	\$13,605.00	\$29,820.00	\$43,425.00		\$43,425.00	
Geauga Highway Company	\$20,000.00	\$27,000.00	\$47,000.00		\$47,000.00	
Eclipse Co., LLC	\$28,633.80	\$19,089.20	\$47,723.00		\$47,723.00	
Great Lakes Crushing, LTD	\$15,000.00	\$34,000.00	\$49,000.00		\$49,000.00	

Depot Street Storm Sewer
City of Geneva
Bid Opening Date: April 09, 2026
Bid Tabulation Summary

Project No. 0000034124

LIST OF BIDDERS

BIDDER

- 1 Great Lakes Crushing, LTD
30831 Euclid Avenue
Willowick, OH 44092
Phone number: (440) 944-5500

- 2 S.E.T. Inc.
235 East Water Street, Suite C
Lowellville, OH 444361273
Phone number: (330) 536-6724

- 3 Geauga Highway Company
15651 W. High Street, Unit 2
Middlefield, OH 44062
Phone number: (440) 834-4850

- 4 Eclipse Co., LLC
11554 East Washington
Chagrin Falls, OH 44023
Phone number: (440) 543-3493

Depot Street Storm Sewer
City of Geneva
Bid Opening Date: April 09, 2026
Bid Tabulation Summary

Project No. 0000034124

LIST OF TOTALS

NOTE: Bidders Informal Totals appear if different than bid tab calculated total.

	<u>Name</u>	<u>Calculated Total</u>	<u>Bidder's Informal Totals</u>
1.	Great Lakes Crushing, LTD	\$126,905.00	
2.	S.E.T. Inc.	\$145,439.00	
3.	Geauga Highway Company	\$147,622.00	
4.	Eclipse Co., LLC	\$185,139.54	\$185,139.53

Depot Street Storm Sewer
City of Geneva
Bid Opening Date: April 09, 2026
Bid Tabulation Summary

Project No. 0000034124

LIST OF ALL ITEMS

NOTE: Bidders Informal unit price or item total appear if different than bid tab calculated price.

<u>Bidders</u>	<u>Labor</u>	<u>Material</u>	<u>Calculated Unit Price</u>	<u>Bidder's Informal Unit Price</u>	<u>Calculated Line Item Total</u>	<u>Bidder's Informal Line Item Total</u>
1. 1.00 LS OF (SPC) BONDS AND INSURANCES, AS PER PLAN						
Great Lakes Crushing, LTD	\$0.00	\$4,500.00	\$4,500.00		\$4,500.00	
S.E.T. Inc.	\$2,000.00	\$0.00	\$2,000.00		\$2,000.00	
Geauga Highway Company	\$40,000.00	\$0.00	\$40,000.00		\$40,000.00	
Eclipse Co., LLC	\$0.00	\$2,031.54	\$2,031.54		\$2,031.54	
2. 17.00 FT OF (202) CURB REMOVED, AS PER PLAN						
Great Lakes Crushing, LTD	\$12.00	\$2.00	\$14.00		\$238.00	
S.E.T. Inc.	\$10.00	\$0.00	\$10.00		\$170.00	
Geauga Highway Company	\$15.00	\$0.00	\$15.00		\$255.00	
Eclipse Co., LLC	\$40.20	\$26.80	\$67.00		\$1,139.00	
3. 190.00 FT OF (202) PIPE REMOVED, 24 INCH AND UNDER						
Great Lakes Crushing, LTD	\$35.00	\$3.00	\$38.00		\$7,220.00	
S.E.T. Inc.	\$10.00	\$0.00	\$10.00		\$1,900.00	
Geauga Highway Company	\$13.00	\$0.00	\$13.00		\$2,470.00	
Eclipse Co., LLC	\$33.00	\$22.00	\$55.00		\$10,450.00	
4. 1.00 EACH OF (202) MANHOLE REMOVED						
Great Lakes Crushing, LTD	\$1,500.00	\$350.00	\$1,850.00		\$1,850.00	
S.E.T. Inc.	\$400.00	\$0.00	\$400.00		\$400.00	
Geauga Highway Company	\$2,000.00	\$0.00	\$2,000.00		\$2,000.00	
Eclipse Co., LLC	\$2,119.20	\$1,412.80	\$3,532.00		\$3,532.00	
5. 2.00 EACH OF (202) CATCH BASIN REMOVED						
Great Lakes Crushing, LTD	\$1,000.00	\$350.00	\$1,350.00		\$2,700.00	
S.E.T. Inc.	\$400.00	\$0.00	\$400.00		\$800.00	
Geauga Highway Company	\$1,000.00	\$0.00	\$1,000.00		\$2,000.00	
Eclipse Co., LLC	\$1,881.00	\$1,254.00	\$3,135.00		\$6,270.00	

Depot Street Storm Sewer
City of Geneva
Bid Opening Date: April 09, 2026
Bid Tabulation Summary

Project No. 0000034124

LIST OF ALL ITEMS
NOTE: Bidders Informal unit price or item total appear if different than bid tab calculated price.

Bidders	Labor	Material	Calculated Unit Price	Bidder's Informal Unit Price	Calculated Line Item Total	Bidder's Informal Line Item Total
6. 145.00 SY OF (SPC) TYPE "C" PAVEMENT REPLACEMENT (ASPHALT), ROADWAY, AS PER PLAN						
Great Lakes Crushing, LTD	\$30.00	\$122.00	\$152.00		\$22,040.00	
S.E.T. Inc.	\$68.10	\$85.00	\$153.10		\$22,199.50	
Geauga Highway Company	\$50.00	\$50.00	\$100.00		\$14,500.00	
Eclipse Co., LLC	\$116.70	\$77.80	\$194.50		\$28,202.50	
7. 1.00 EACH OF (SPC) FIELD TEE CONNECTION, AS PER PLAN						
Great Lakes Crushing, LTD	\$2,800.00	\$1,450.00	\$4,250.00		\$4,250.00	
S.E.T. Inc.	\$599.62	\$400.00	\$999.62		\$999.62	
Geauga Highway Company	\$1,500.00	\$0.00	\$1,500.00		\$1,500.00	
Eclipse Co., LLC	\$1,602.90	\$1,068.60	\$2,671.50		\$2,671.50	
8. 2.00 EACH OF (SPC) BULKHEAD EXISTING PIPE, AS PER PLAN						
Great Lakes Crushing, LTD	\$1,650.00	\$350.00	\$2,000.00		\$4,000.00	
S.E.T. Inc.	\$250.00	\$250.00	\$500.00		\$1,000.00	
Geauga Highway Company	\$2,000.00	\$0.00	\$2,000.00		\$4,000.00	
Eclipse Co., LLC	\$612.30	\$408.20	\$1,020.50		\$2,041.00	
9. 16.00 FT OF (611) 12" CONDUIT, TYPE B, AS PER PLAN						
Great Lakes Crushing, LTD	\$44.00	\$61.00	\$105.00		\$1,680.00	
S.E.T. Inc.	\$139.48	\$82.18	\$221.66		\$3,546.56	
Geauga Highway Company	\$100.00	\$100.00	\$200.00		\$3,200.00	
Eclipse Co., LLC	\$96.60	\$64.40	\$161.00		\$2,576.00	
10. 22.00 FT OF (611) 15" CONDUIT, TYPE B, AS PER PLAN						
Great Lakes Crushing, LTD	\$44.00	\$63.00	\$107.00		\$2,354.00	
S.E.T. Inc.	\$131.92	\$85.18	\$217.10		\$4,776.20	
Geauga Highway Company	\$100.00	\$100.00	\$200.00		\$4,400.00	
Eclipse Co., LLC	\$87.90	\$58.60	\$146.50		\$3,223.00	

Depot Street Storm Sewer
City of Geneva
Bid Opening Date: April 09, 2026
Bid Tabulation Summary

Project No. 0000034124

LIST OF ALL ITEMS
NOTE: Bidders Informal unit price or item total appear if different than bid tab calculated price.

	<u>Bidders</u>	<u>Labor</u>	<u>Material</u>	<u>Calculated Unit Price</u>	<u>Bidder's Informal Unit Price</u>	<u>Calculated Line Item Total</u>	<u>Bidder's Informal Line Item Total</u>
11.	205.00 FT OF (611) 18" CONDUIT, TYPE B, AS PER PLAN						
	Great Lakes Crushing, LTD	\$44.00	\$85.00	\$129.00		\$26,445.00	
	S.E.T. Inc.	\$76.44	\$116.62	\$193.06		\$39,577.30	
	Geauga Highway Company	\$100.00	\$50.00	\$150.00		\$30,750.00	
	Eclipse Co., LLC	\$150.90	\$100.60	\$251.50		\$51,557.50	
12.	38.00 FT OF (611) 8 INCH - 15 INCH CONDUIT INTERNAL TELEVISION INSPECTION, INCLUDING LIGHT CLEANING, AS PER PLA						
	Great Lakes Crushing, LTD	\$9.00	\$12.00	\$21.00		\$798.00	
	S.E.T. Inc.	\$10.00	\$0.00	\$10.00		\$380.00	
	Geauga Highway Company	\$19.00	\$0.00	\$19.00		\$722.00	
	Eclipse Co., LLC	\$8.70	\$5.80	\$14.50		\$551.00	
13.	205.00 FT OF (611) 18 INCH - 24 INCH CONDUIT INTERNAL TELEVISION INSPECTION, INCLUDING LIGHT CLEANING, AS PER PI						
	Great Lakes Crushing, LTD	\$9.00	\$12.00	\$21.00		\$4,305.00	
	S.E.T. Inc.	\$10.00	\$0.00	\$10.00		\$2,050.00	
	Geauga Highway Company	\$25.00	\$0.00	\$25.00		\$5,125.00	
	Eclipse Co., LLC	\$8.70	\$5.80	\$14.50		\$2,972.50	
14.	1.00 EACH OF (611) CATCH BASIN CURB INLET, AS PER PLAN						
	Great Lakes Crushing, LTD	\$3,500.00	\$2,675.00	\$6,175.00		\$6,175.00	
	S.E.T. Inc.	\$1,102.80	\$1,729.88	\$2,832.68		\$2,832.68	
	Geauga Highway Company	\$2,000.00	\$2,000.00	\$4,000.00		\$4,000.00	
	Eclipse Co., LLC	\$2,638.50	\$1,759.00	\$4,397.50		\$4,397.50	
15.	3.00 EACH OF (611) 48 INCH STORM MANHOLE, AS PER PLAN						
	Great Lakes Crushing, LTD	\$3,500.00	\$3,450.00	\$6,950.00		\$20,850.00	
	S.E.T. Inc.	\$1,338.00	\$3,836.70	\$5,174.70		\$15,524.10	
	Geauga Highway Company	\$2,000.00	\$2,400.00	\$4,400.00		\$13,200.00	
	Eclipse Co., LLC	\$5,034.30	\$3,356.20	\$8,390.50		\$25,171.50	

Depot Street Storm Sewer
City of Geneva
Bid Opening Date: April 09, 2026
Bid Tabulation Summary

Project No. 0000034124

LIST OF ALL ITEMS
NOTE: Bidders Informal unit price or item total appear if different than bid tab calculated price.

<u>Bidders</u>	<u>Labor</u>	<u>Material</u>	<u>Calculated Unit Price</u>	<u>Bidder's Informal Unit Price</u>	<u>Calculated Line Item Total</u>	<u>Bidder's Informal Line Item Total</u>
16. 2.00 EACH OF (638) 6 INCH WATER MAIN LOWERING, AS PER PLAN						
Great Lakes Crushing, LTD	\$3,200.00	\$1,800.00	\$5,000.00		\$10,000.00	
S.E.T. Inc.	\$13,400.00	\$6,491.52	\$19,891.52		\$39,783.04	
Geauga Highway Company	\$3,000.00	\$3,000.00	\$6,000.00		\$12,000.00	
Eclipse Co., LLC	\$9,255.90	\$6,170.60	\$15,426.50		\$30,853.00	
17. 1.00 LS OF (SPC) CONTINGENCY/DISCRETIONARY ALLOWANCE						
Great Lakes Crushing, LTD	\$7,500.00	\$0.00	\$7,500.00		\$7,500.00	
S.E.T. Inc.	\$7,500.00	\$0.00	\$7,500.00		\$7,500.00	
Geauga Highway Company	\$7,500.00	\$0.00	\$7,500.00		\$7,500.00	
Eclipse Co., LLC	\$7,500.00	\$0.00	\$7,500.00		\$7,500.00	

It is hereby mutually agreed that the OWNER is to pay and the CONTRACTOR is to receive, as full compensation for furnishing all materials and labor in building, constructing and testing and in all respect completing the herein described work and appurtenances in the manner and under the conditions herein specified, the prices stipulated in the proposal herein contained or hereto annexed and the total contract sum is \$1,075,161.35.

This Contract shall be in full force and effect from the date of execution by the parties.

IN WITNESS WHEREOF: The parties hereunto affixed their signature the day and year first mentioned above.

GEAUGA HIGHWAY CO.



John Bojco, President

CITY OF GENEVA



Joseph Varckette, City Manager

I hereby certify that funds in the amount of One Million Seventy-Five Thousand One Hundred Sixty-One 35/100 Dollars \$1,075,161.35) necessary for the foregoing Contract have been appropriated and are in the Treasury, or are in the process of collection, or are available through grants and/or loans from other funding sources.



Traci Welch, Finance Director

APPROVED AS TO FORM:

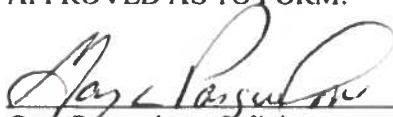

Gary Pasqualone, Solicitor

CDBG RECIPIENT: ASHTABULA COUNTY BOARD OF COMMISSIONERS (Depot Street)



Casey R. Kozlowski, President

CDBG RECIPIENT: ASHTABULA COUNTY COMMISSIONERS HOLD HARMLESS

The Owner and Contractor agree to hold the Ashtabula County Board of Commissioners (CDBG Recipient) harmless from and against claims, damages, losses, and expense, including but not limited to attorney's fees, arising out of or resulting from negligence or misconduct in relation to the work defined in the contract.

Signature Page

AGREEMENT TITLE: CONTRACT FOR GENEVA STREETScape IMPROVEMENTS

APPROVED as to Legal Form Only.

Approved by:  _____
April R. Grabman
Ashtabula County Prosecutor

Dated: 5/17/26

Reviewed by Earl F. Stoll, Assistant Prosecutor 

FISCAL OFFICER'S CERTIFICATE

5705.41 O.R.C.

The undersigned, County Auditor of Ashtabula County, hereby certifies that the amount required to meet the obligations of the County during the year 2026 under the Agreement has been lawfully appropriated for that purpose, and is in the Treasury of the County or in the process of collection to the credit of:

Total contract sum not to exceed \$1,075,161.35 of which the CDBG recipient is responsible to pay an amount not to exceed \$153,000.00 from 2701.511.527-650.0101 of the total contracted amount.

Agreement Title: GENEVA STREETScape IMPROVEMENTS
Depot Street Storm Sewer – CDBG Funded (City of Geneva)

Between: Third Party Agreement between Geauga Highway Co., the City of Geneva, and CDBG Recipient: Ashtabula County Board of Commissioners, for the **GENEVA STREETScape IMPROVEMENTS - DEPOT STREET STORM SEWER.** (CDBG PY 2025 Activity 1.1).



Scott Yamamoto
Ashtabula County Auditor

Date: 5/5/2026



To: All Plan Holders of Record

From: Verdantas LLC
For the Owner

Re: *Addendum No. 1*
Geneva Streetscape Improvements
City of Geneva

Date: March 30, 2026

This Addendum forms a part of the contract documents and modifies the original bidding documents dated March 2026 and all previous addenda, if any. Acknowledge receipt of this addendum in the space provided in the bid forms. Failure to do so may subject the bidder to disqualification.

QUESTIONS AND ANSWERS

Q1. The plans call out for the contractor to core into the existing footer of the signal pole to draw power for the proposed clock tower. Per discussions with our Electrical contractor, they recommend either channeling the existing foundation to hide the conduit or replacing the entire signal foundation.

A1. Contractor shall channel the existing pedestrian signal pole foundation to hide the conduit.

Q2. Sign Lighting – Will the Proposed lights need to sit on a concrete foundation?

A2. Footer description has been added 129300 SITE FURNISHINGS

Q3. Can the City please identify which pipes we are to Abandon and Fill with Grout and which pipes we are to Remove?

A3. Pipes that are within the construction limits of new storm sewers will need to be removed. Storm sewers under pavement but not within the construction limits of new sewers, will need to be abandoned and grout filled.

BID FORMS

Replace Bid Form, Pages BF.8 and BF.13, with the enclosed Bid Form, Pages BF 8A and BF.13A.

SPECIFICATIONS

In Specification Section 129300 **Revise** the following paragraph to section 3.1 after paragraph B.:

3. Sign uprights

- a. Install light fixtures with knuckle mount on waterproof electrical box bolted to cast-in-place 8" dia x 24" concrete footer with stainless steel anchors. Fixture to be aimed in field and knuckle fully locked to prevent rotation or movement.

PLANS

On plan sheet 03/21 **Add** Full Depth Pavement Sawcut along the north edge of the parking lot to create a clean straight edge that matches the new parking lot layout. Additional quantity has been added to the Bid Forms.

Add attached Water Main Lowering Detail

LH:sp

Enclosures

Z:\Project Files\GA-HZ\Geneva\31538 - Geneva Appalachian Community Grant Imp\Working\Bid Documents\Phase 2 - Geneva Streetscape Improvements\Addenda\Addendum 01.Doc

**Proposal to City of Geneva
For Appalachian Community Grant Improvements
Geneva Streetscape Improvements - Phase 2 - Base Bid
Project No. 0000031538**

REF. NO.	DESCRIPTION	QTY.	MEASURE UNITS	UNIT PRICE LABOR	UNIT PRICE MATERIAL	TOTAL UNIT PRICE	ITEM TOTAL
1	(SPC) PRECONSTRUCTION VIDEO DOCUMENTATION	1.00	LS	\$	\$	\$	\$
2	(SPC) BONDS AND INSURANCES, AS PER PLAN	1.00	LS	\$	\$	\$	\$
3	(202) EXCAVATION AND REMOVAL OF EXISTING PAVEMENT & BASE, AS PER PLAN	885.00	SY	\$	\$	\$	\$
4	(202) CURB REMOVED, AS PER PLAN	28.50	FT	\$	\$	\$	\$
5	(202) PIPE REMOVED, 24 INCH AND UNDER	396.00	FT	\$	\$	\$	\$
6	(202) STORM SEWER ABANDONED, GROUT FILLED, AS PER PLAN	165.00	FT	\$	\$	\$	\$
7	(202) MANHOLE REMOVED	1.00	EACH	\$	\$	\$	\$
8	(202) CATCH BASIN REMOVED	7.00	EACH	\$	\$	\$	\$
9	(202) REMOVAL MISC.: MISC. SITE ITEMS	1.00	LS	\$	\$	\$	\$
10	(203) EMBANKMENT, AS PER PLAN	1.00	LS	\$	\$	\$	\$
11	(SPC) SPECIAL - BIORETENTION CELL, AS PER PLAN	1.00	EACH	\$	\$	\$	\$
12	(251) PARTIAL DEPTH PAVEMENT REPAIR, AS PER PLAN	75.00	CY	\$	\$	\$	\$
13	(253) PAVEMENT REPAIR, AS PER PLAN	75.00	CY	\$	\$	\$	\$
14	(SPC) TYPE "C" PAVEMENT REPLACEMENT (ASPHALT), ROADWAY, AS PER PLAN	23.00	SY	\$	\$	\$	\$
15	(254) PAVEMENT PLANING, ASPHALT CONCRETE, AS PER PLAN	5,327.00	SY	\$	\$	\$	\$
16	(255) FULL DEPTH PAVEMENT SAWING, AS PER PLAN	2,043.00	FT	\$	\$	\$	\$
17	(301) ASPHALT CONCRETE BASE, PG64-22, AS PER PLAN	70.00	CY	\$	\$	\$	\$
18	(407) TACK COAT	480.00	GAL	\$	\$	\$	\$
19	(441) ASPHALT CONCRETE INTERMEDIATE COURSE, TYPE 1, (448), VARIABLE THICKNESS, AS PER PLAN	370.00	CY	\$	\$	\$	\$
20	(448) ASPHALT CONCRETE SURFACE COURSE, TYPE 1, PG64-22, AS PER PLAN	222.00	CY	\$	\$	\$	\$
21	(451) 8 INCH REINFORCED CONCRETE DRIVES AND APRONS, CLASS QCMS, INCLUDING INTEGRAL COLOR, AS PER PLAN	36.00	SY	\$	\$	\$	\$
22	(608) 4 INCH CONCRETE WALK, AS PER PLAN	272.00	SF	\$	\$	\$	\$

**Proposal to City of Geneva
For Depot Street Storm Sewer**

Project No. 0000034124

REF. NO.	DESCRIPTION	QTY.	MEASURE UNITS	UNIT PRICE LABOR	UNIT PRICE MATERIAL	TOTAL UNIT PRICE	ITEM TOTAL
1	(202) CURB REMOVED, AS PER PLAN	17.00	FT	\$	\$	\$	\$
2	(202) PIPE REMOVED, 24 INCH AND UNDER	190.00	FT	\$	\$	\$	\$
3	(202) MANHOLE REMOVED	1.00	EACH	\$	\$	\$	\$
4	(202) CATCH BASIN REMOVED	2.00	EACH	\$	\$	\$	\$
5	(SPC) TYPE "C" PAVEMENT REPLACEMENT (ASPHALT), ROADWAY, AS PER PLAN	145.00	SY	\$	\$	\$	\$
6	(SPC) FIELD TEE CONNECTION, AS PER PLAN	1.00	EACH	\$	\$	\$	\$
7	(SPC) BULKHEAD EXISTING PIPE, AS PER PLAN	2.00	EACH	\$	\$	\$	\$
8	(611) 12" CONDUIT, TYPE B, AS PER PLAN	16.00	FT	\$	\$	\$	\$
9	(611) 15" CONDUIT, TYPE B, AS PER PLAN	22.00	FT	\$	\$	\$	\$
10	(611) 18" CONDUIT, TYPE B, AS PER PLAN	205.00	FT	\$	\$	\$	\$
11	(611) CATCH BASIN CURB INLET, AS PER PLAN	1.00	EACH	\$	\$	\$	\$
12	(611) 48 INCH STORM MANHOLE, AS PER PLAN	3.00	EACH	\$	\$	\$	\$
13	(638) 6 INCH WATER MAIN LOWERING, AS PER PLAN	2.00	EACH	\$	\$	\$	\$
14	(SPC) CONTINGENCY/DISCRETIONARY ALLOWANCE	1.00	LS	\$	\$	\$	\$
INFORMAL TOTAL BID						\$	\$

NOTES:

1. ENTIRE OFFSET INCLUDING BENDS SHALL BE BUILT WITH DUCTILE IRON RESTRAINED MECHANICAL JOINTS, CLASS 52 . IF AN INTERMEDIATE JOINT IS REQUIRED BETWEEN BENDS, THE ENTIRE UNDERPASS SHALL BE BUILT WITH BOLTLESS RESTRAINED PIPE AND FITTINGS.

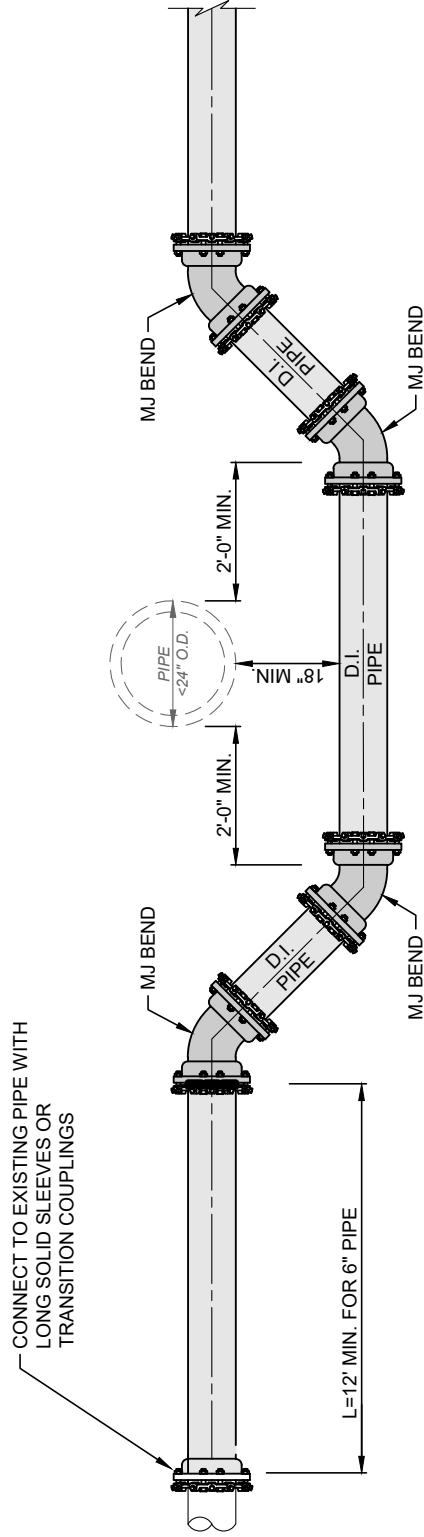

FOR OBSTRUCTION LESS THAN 24" DIA. OR WIDTH

WATER MAIN LOWERING DETAIL

SCALE: NONE



To: All Plan Holders of Record

From: Verdantas LLC
For the Owner

Re: *Addendum No. 2*
Geneva Streetscape Improvements
City of Geneva

Date: April 1, 2026

This Addendum forms a part of the contract documents and modifies the original bidding documents dated March 2026 and all previous addenda, if any. Acknowledge receipt of this addendum in the space provided in the bid forms. Failure to do so may subject the bidder to disqualification.

BID OPENING DATE

The date of receiving and opening bids shall be changed from April 2, 2026 to April 9, 2026. The time and place shall remain the same.

LH:mep

Z:\Project Files\GA-HZ\Geneva\31538 - Geneva Appalachian Community Grant Imp\Working\Bid Documents\Phase 2 - Geneva Streetscape Improvements\Addenda\Addendum 02\Addendum 02.Doc



To: All Plan Holders of Record

From: Verdantas LLC
For the Owner

Re: *Addendum No. 3*
Geneva Streetscape Improvements
City of Geneva

Date: April 6, 2026

This Addendum forms a part of the contract documents and modifies the original bidding documents dated March 2026 and all previous addenda, if any. Acknowledge receipt of this addendum in the space provided in the bid forms. Failure to do so may subject the bidder to disqualification.

OPINION OF PROBABLE CONSTRUCTION COST

The Opinion of Probable Construction Cost as published in the Legal Notice shall be changed from \$900,000 to \$950,000 for the Phase 2 – Streetscape Base Bid.

BID DOCUMENTS

Add the following to the Prices to Include:

(611) 8-INCH – 15-INCH CONDUIT INTERNAL TELEVISION INSPECTION, INCLUDING LIGHT CLEANING, AS PER PLAN

Method of Measurement

The quantity to be paid for the internal television inspection shall be the linear foot of televised new installed storm sewer pipe.

Basis of Payment

The unit price for the various sizes of pipe shall include mobilization, setup, measuring pipe diameters and depths, light cleaning of the sewer using sewer jet, hauling available water for cleaning and dye testing, sewer flow control, televising the sewer pipe and manhole troughs, using pipe locating equipment, televising sewer connections by positioning the camera, rotating the camera head, and recording the observations, videotapes, inspection logs, and the furnishing of all labor, material, tools and appurtenances necessary to complete the work as specified or as shown. Video on acceptable medium and logs shall be turned over to the Owner prior to payment for this item.

Addendum No. 3
Date: April 6, 2026
Page 2

BID FORMS

Replace Bid Form, Pages BF.9 to BF.12, with the enclosed Bid Form, Pages BF.9A to BF.12A and Bid Form, Pages BF.13A, with the enclosed Bid Form, Pages BF.13B.

Attached is the complete set of proposal items sheets BF.8A to 12A, BF.13B and BF.14 to be submitted.

LH:mep

Z:\Project Files\GA-HZ\Geneva\31538 - Geneva Appalachian Community Grant Imp\Working\Bid Documents\Phase 2 - Geneva Streetscape Improvements\Addenda\Addendum 03\Addendum 03.Doc

**Proposal to City of Geneva
For Appalachian Community Grant Improvements
Geneva Streetscape Improvements - Phase 2 - Base Bid
Project No. 0000031538**

REF. NO.	DESCRIPTION	QTY.	MEASURE UNITS	UNIT PRICE LABOR	UNIT PRICE MATERIAL	TOTAL UNIT PRICE	ITEM TOTAL
1	(SPC) PRECONSTRUCTION VIDEO DOCUMENTATION	1.00	LS	\$	\$	\$	\$
2	(SPC) BONDS AND INSURANCES, AS PER PLAN	1.00	LS	\$	\$	\$	\$
3	(202) EXCAVATION AND REMOVAL OF EXISTING PAVEMENT & BASE, AS PER PLAN	885.00	SY	\$	\$	\$	\$
4	(202) CURB REMOVED, AS PER PLAN	28.50	FT	\$	\$	\$	\$
5	(202) PIPE REMOVED, 24 INCH AND UNDER	396.00	FT	\$	\$	\$	\$
6	(202) STORM SEWER ABANDONED, GROUT FILLED, AS PER PLAN	165.00	FT	\$	\$	\$	\$
7	(202) MANHOLE REMOVED	1.00	EACH	\$	\$	\$	\$
8	(202) CATCH BASIN REMOVED	7.00	EACH	\$	\$	\$	\$
9	(202) REMOVAL MISC.: MISC. SITE ITEMS	1.00	LS	\$	\$	\$	\$
10	(203) EMBANKMENT, AS PER PLAN	1.00	LS	\$	\$	\$	\$
11	(SPC) SPECIAL - BIORETENTION CELL, AS PER PLAN	1.00	EACH	\$	\$	\$	\$
12	(251) PARTIAL DEPTH PAVEMENT REPAIR, AS PER PLAN	75.00	CY	\$	\$	\$	\$
13	(253) PAVEMENT REPAIR, AS PER PLAN	75.00	CY	\$	\$	\$	\$
14	(SPC) TYPE "C" PAVEMENT REPLACEMENT (ASPHALT), ROADWAY, AS PER PLAN	23.00	SY	\$	\$	\$	\$
15	(254) PAVEMENT PLANING, ASPHALT CONCRETE, AS PER PLAN	5,327.00	SY	\$	\$	\$	\$
16	(255) FULL DEPTH PAVEMENT SAWING, AS PER PLAN	2,043.00	FT	\$	\$	\$	\$
17	(301) ASPHALT CONCRETE BASE, PG64-22, AS PER PLAN	70.00	CY	\$	\$	\$	\$
18	(407) TACK COAT	480.00	GAL	\$	\$	\$	\$
19	(441) ASPHALT CONCRETE INTERMEDIATE COURSE, TYPE 1, (448), VARIABLE THICKNESS, AS PER PLAN	370.00	CY	\$	\$	\$	\$
20	(448) ASPHALT CONCRETE SURFACE COURSE, TYPE 1, PG64-22, AS PER PLAN	222.00	CY	\$	\$	\$	\$
21	(451) 8 INCH REINFORCED CONCRETE DRIVES AND APRONS, CLASS QCMS, INCLUDING INTEGRAL COLOR, AS PER PLAN	36.00	SY	\$	\$	\$	\$
22	(608) 4 INCH CONCRETE WALK, AS PER PLAN	272.00	SF	\$	\$	\$	\$

**Proposal to City of Geneva
For Appalachian Community Grant Improvements
Geneva Streetscape Improvements - Phase 2 - Base Bid
Project No. 0000031538**

REF. NO.	DESCRIPTION	QTY.	MEASURE UNITS	UNIT PRICE LABOR	UNIT PRICE MATERIAL	TOTAL UNIT PRICE	ITEM TOTAL
23	(608) CURB RAMP, AS PER PLAN	149.00	SF	\$	\$	\$	\$
24	(608) DETECTABLE WARNING, AS PER PLAN	30.00	SF	\$	\$	\$	\$
25	(609) CURB, TYPE 6, AS PER PLAN	1,078.00	FT	\$	\$	\$	\$
26	(SPC) CURB, MISC.: FLUSH CURB, AS PER PLAN	82.00	FT	\$	\$	\$	\$
27	(611) 12" CONDUIT, TYPE B, AS PER PLAN	189.00	FT	\$	\$	\$	\$
28	(611) 18" CONDUIT, TYPE B, AS PER PLAN	316.00	FT	\$	\$	\$	\$
29	(611) CONDUIT, MISC.: CONNECTION OF CONDUIT TO EXISTING DRAINAGE STRUCTURE	2.00	EACH	\$	\$	\$	\$
30	(611) 8 INCH - 15 INCH CONDUIT INTERNAL TELEVISION INSPECTION, INCLUDING LIGHT CLEANING, AS PER PLAN	189.00	FT	\$	\$	\$	\$
31	(611) 18 INCH - 24 INCH CONDUIT INTERNAL TELEVISION INSPECTION, INCLUDING LIGHT CLEANING, AS PER PLAN	316.00	FT	\$	\$	\$	\$
32	(611) CATCH BASIN, NO. 2-2B, AS PER PLAN	6.00	EACH	\$	\$	\$	\$
33	(611) CATCH BASIN CURB INLET, AS PER PLAN	1.00	EACH	\$	\$	\$	\$
34	(611) 48 INCH STORM MANHOLE, AS PER PLAN	2.00	EACH	\$	\$	\$	\$
35	(611) MANHOLE ADJUSTED TO GRADE, AS PER PLAN	1.00	EACH	\$	\$	\$	\$
36	(614) MAINTAINING TRAFFIC	1.00	LS	\$	\$	\$	\$
37	(623) CONSTRUCTION LAYOUT STAKES AND SURVEYING, AS PER PLAN	1.00	LS	\$	\$	\$	\$
38	(624) MOBILIZATION	1.00	LS	\$	\$	\$	\$
39	(630) SIGN, FLAT SHEET, WITH MOUNTING POST	20.00	EACH	\$	\$	\$	\$
40	(638) 6 INCH FIRE HYDRANT ASSEMBLY, INCLUDING 6 INCH VALVE AND VALVE BOX, TYPE A, AS PER PLAN	1.00	EACH	\$	\$	\$	\$
41	(638) FIRE HYDRANT & VALVE BOX REMOVED AND DISPOSED, AS PER PLAN	1.00	EACH	\$	\$	\$	\$
42	(642) TRAFFIC PAINT, AS PER PLAN	1.00	LS	\$	\$	\$	\$
43	(659) TOPSOIL, AS PER PLAN	96.00	CY	\$	\$	\$	\$
44	(659) SEEDING AND MULCHING, AS PER PLAN	1.00	LS	\$	\$	\$	\$

**Proposal to City of Geneva
For Appalachian Community Grant Improvements
Geneva Streetscape Improvements - Phase 2 - Base Bid
Project No. 0000031538**

REF. NO.	DESCRIPTION	QTY.	MEASURE UNITS	UNIT PRICE LABOR	UNIT PRICE MATERIAL	TOTAL UNIT PRICE	ITEM TOTAL
45	(661) MULCH, AS PER PLAN	11.00	CY	\$	\$	\$	\$
46	(661) STONE MULCH, AS PER PLAN	7.00	CY	\$	\$	\$	\$
47	(661) PERENNIALS	44.00	EACH	\$	\$	\$	\$
48	(661) DECIDUOUS SHRUB, 18 INCH HEIGHT	9.00	EACH	\$	\$	\$	\$
49	(661) EVERGREEN SHRUB, 12 INCH HEIGHT	9.00	EACH	\$	\$	\$	\$
50	(661) DECIDUOUS TREE, 1-1/2 INCH CALIPER	18.00	EACH	\$	\$	\$	\$
51	(661) DECIDUOUS TREE, 2 INCH CALIPER	5.00	EACH	\$	\$	\$	\$
52	(661) EVERGREEN TREE, 5' HEIGHT	16.00	EACH	\$	\$	\$	\$
53	(SPC) TEMPORARY SEDIMENT AND EROSION CONTROL, AS PER PLAN	1.00	LS	\$	\$	\$	\$
54	(SPC) CONTINGENCY/DISCRETIONARY ALLOWANCE	1.00	LS	\$ -----	\$ -----	\$ 100,000.00	\$ 100,000.00
INFORMAL TOTAL BID						\$	\$

**Proposal to City of Geneva
 For Appalachian Community Grant Improvements
 Geneva Streetscape Improvements - Phase 2 - Alternate A - Decorative Sign
 Project No. 0000031538**

REF. NO.	DESCRIPTION	QTY.	MEASURE UNITS	UNIT PRICE LABOR	UNIT PRICE MATERIAL	TOTAL UNIT PRICE	ITEM TOTAL
1	(SPC) BONDS AND INSURANCES, AS PER PLAN	1.00	LS	\$ _____	\$ _____	\$ _____	\$ _____
2	(SPC) DECORATIVE SIGN, AS PER PLAN	1.00	EACH	\$ _____	\$ _____	\$ _____	\$ _____
				INFORMAL TOTAL BID \$ _____			

**Proposal to City of Geneva
 For Appalachian Community Grant Improvements
 Geneva Streetscape Improvements - Phase 2 - Alternate B - Decorative Clock
 Project No. 0000031538**

REF. NO.	DESCRIPTION	QTY.	MEASURE UNITS	UNIT PRICE LABOR	UNIT PRICE MATERIAL	TOTAL UNIT PRICE	ITEM TOTAL
1	(SPC) BONDS AND INSURANCES, AS PER PLAN	1.00	LS	\$ _____	\$ _____	\$ _____	\$ _____
2	(SPC) DECORATIVE CLOCK, AS PER PLAN	1.00	EACH	\$ _____	\$ _____	\$ _____	\$ _____
				INFORMAL TOTAL BID \$ _____			

**Proposal to City of Geneva
For Depot Street Storm Sewer**

Project No. 0000034124

REF. NO.	DESCRIPTION	QTY.	MEASURE UNITS	UNIT PRICE LABOR	UNIT PRICE MATERIAL	TOTAL UNIT PRICE	ITEM TOTAL
1	(SPC) BONDS AND INSURANCES, AS PER PLAN	1.00	LS	\$	\$	\$	\$
2	(202) CURB REMOVED, AS PER PLAN	17.00	FT	\$	\$	\$	\$
3	(202) PIPE REMOVED, 24 INCH AND UNDER	190.00	FT	\$	\$	\$	\$
4	(202) MANHOLE REMOVED	1.00	EACH	\$	\$	\$	\$
5	(202) CATCH BASIN REMOVED	2.00	EACH	\$	\$	\$	\$
6	(SPC) TYPE "C" PAVEMENT REPLACEMENT (ASPHALT), ROADWAY, AS PER PLAN	145.00	SY	\$	\$	\$	\$
7	(SPC) FIELD TEE CONNECTION, AS PER PLAN	1.00	EACH	\$	\$	\$	\$
8	(SPC) BULKHEAD EXISTING PIPE, AS PER PLAN	2.00	EACH	\$	\$	\$	\$
9	(611) 12" CONDUIT, TYPE B, AS PER PLAN	16.00	FT	\$	\$	\$	\$
10	(611) 15" CONDUIT, TYPE B, AS PER PLAN	22.00	FT	\$	\$	\$	\$
11	(611) 18" CONDUIT, TYPE B, AS PER PLAN	205.00	FT	\$	\$	\$	\$
12	(611) 8 INCH - 15 INCH CONDUIT INTERNAL TELEVISION INSPECTION, INCLUDING LIGHT CLEANING, AS PER PLAN	38.00	FT	\$	\$	\$	\$
13	(611) 18 INCH - 24 INCH CONDUIT INTERNAL TELEVISION INSPECTION, INCLUDING LIGHT CLEANING, AS PER PLAN	205.00	FT	\$	\$	\$	\$
14	(611) CATCH BASIN CURB INLET, AS PER PLAN	1.00	EACH	\$	\$	\$	\$
15	(611) 48 INCH STORM MANHOLE, AS PER PLAN	3.00	EACH	\$	\$	\$	\$
16	(638) 6 INCH WATER MAIN LOWERING, AS PER PLAN	2.00	EACH	\$	\$	\$	\$
17	(SPC) CONTINGENCY/DISCRETIONARY ALLOWANCE	1.00	LS	\$ -----	\$ -----	\$ 7,500.00	\$ 7,500.00
INFORMAL TOTAL BID						\$	\$

The Bidder hereby acknowledges that they have reviewed the following addenda:

Addendum No. _____
Date: _____

The undersigned, having full knowledge of the plans and specifications for the improvements and the conditions of the Proposal hereby agree to furnish all the services, labor, materials, and equipment necessary to complete the work according to the plans and specifications and to accept as full compensation the lump sum or the unit prices specified serving as deduct or extra compensation rates.

And We (or I) do hereby agree that in the event of failure on OUR part to contract as aforesaid (provided this Proposal is accepted) the Bid Bond, Check or Letter of Credit accompanying this Proposal shall be forfeited to the Owner as liquidated damages for the difference between this bid and the awarded Contract price, not to exceed the amount of bond. We further agree that the Owner may reject any or all bids.

By signature below, I hereby certify that **I AND MY Insurance Agent have examined the insurance requirements** in the specifications and that the types and amounts of same are currently in effect or will be obtained and kept in effect for the project duration and that my Insurance Agent has assured that notification of non-renewal, policy modification, and/or cancellation to all certificate holders will occur per the contract requirements. Verification will be provided to the Owner subsequent to the issuance of a Notice of Award.

Submitted by,

Firm, Corporation, or Individual	Officer's Name and Title (typed)	Telephone Number
Street Address	Officer's Signature	Fax Number
City, State, Zip Code	Date	E-Mail Address
Unique Entity Identifier Number (UEI) SAM.gov	Ohio Secretary of State ID Number	Federal Tax ID Number

Note: Evidence of authority to sign must be affixed and attested by the Secretary.

COMPLETION DATE: AUGUST 28, 2026
LIQUIDATED DAMAGES: \$1,000.00 PER DAY